

# ***GM Series***

## **Hydraulic Motor with Reduction Gears Operation Manual**

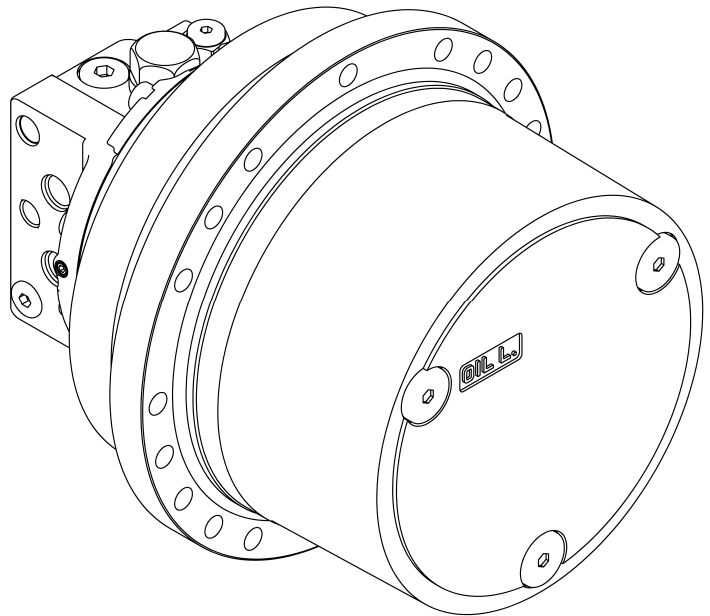

Please be sure to read and understand this manual before using the product.  
The administrator and operator of the product should have access to this manual.  
Store this manual at a specified safe place so that it can be referred to when necessary.



A JV OF COMER INDUSTRIES AND NABTESCO

©Comtesco Corporation All Rights Reserved.

---

## Table of Contents

CONTENTS OF MANUAL.....	3
IMPORTANT NOTICE .....	4
1. Intended Use of Product .....	4
2. Precautions for Safe Use of GM .....	4
3. Notice on the Operation Manual .....	5
4. Disposal of GM .....	5
5. Other Important Notice.....	5
Chapter 1 SAFETY .....	6
1.1. Strict observance and Prohibition .....	6
1.2. Types of Warnings and their Meanings .....	7
1.3. Notation and Meaning of Important Information .....	7
Chapter 2 OVERVIEW OF GM .....	8
2.1. Name of Each Part.....	8
2.2. Storage of GM.....	9
Chapter 3 PREPARATION FOR INSTALLATION.....	10
3.1. Installation Environments .....	10
3.2. Preparation of Necessary Materials.....	10
3.3. Transportation and Unpacking.....	11
Chapter 4 INSTALLATION IN THE MACHINE .....	14
4.1. Precautions on Hoisting .....	14
4.2. Hoisting and Installing GM .....	15
4.3. Hydraulic Piping Connection.....	17
4.4. Trial Run after Installation.....	17
Chapter 5 HYDRAULIC OIL AND LUBRICANT .....	19
5.1. Precautions when Handling Hydraulic Oil and Lubricant .....	19
5.2. Type of Hydraulic Oil .....	20
5.3. Replacing Hydraulic Oil.....	21
5.4. Type of Lubricant and Filling volume .....	22
5.5. Replacing Lubricant .....	22
Chapter 6 MAINTENANCE & INSPECTION .....	26
6.1. Precautions on maintenance and inspection.....	26
6.2. Periodical Inspection .....	26
6.3. Removal from the Machine.....	28
Chapter 7 TROUBLESHOOTING.....	29
CUSTOMER SUPPORT.....	31

## CONTENTS OF MANUAL

This manual consists of the following chapters and references.

Chapter name	Description
IMPORTANT NOTICE	The following are explained: <ul style="list-style-type: none"> <li>▪ Intended use of the product</li> <li>▪ Safety precautions</li> <li>▪ Notice on the Operation Manual</li> <li>▪ Disposal of GM</li> <li>▪ Other important notices</li> </ul>
Ch.1 SAFETY	The information on safety is described as strict observance and prohibition. Safety information such as GM installation is described in Chapter 3 and later.
Ch.2 OVERVIEW OF GM	The name of each part of GM as well as how to store it described.
Ch.3 PREPARATION	Installation environments of GM, preparation of necessary materials, unpacking, and hoisting are described, along with safety precautions.
Ch.4 INSTALLATION	Installation procedure of GM, and precautions to avoid human injuries during installation as well as damage of GM.
Ch.5 HYDRAULIC OIL AND LUBRICANT	The following information on hydraulic oil and lubricant is described: <ul style="list-style-type: none"> <li>▪ Precautions for handling</li> <li>▪ Recommended brand</li> <li>▪ Filling volume</li> <li>▪ Replacing interval and procedure</li> </ul>
Ch.6 MAINTENANCE & INSPECTION	Precautions for maintenance and inspection works, and procedure of periodical inspection and GM removal are described.
Ch.7 TROUBLESHOOTING	How to deal with problems is described.
CUSTOMER SUPPORT	Support contact at our corporation is described.

## IMPORTANT NOTICE

### 1. Intended Use of Product

GM Series; Hydraulic Motor with Reduction Gears (hereafter referred to as GM) is a hydraulic driven rotary actuator. The product contains a reduction gears, a hydraulic motor, a brake valve and a parking brake integrated into one compact unit. It has been developed for use as an actuator for application requiring low-rpm, high torque operation such as construction and marine machinery. In addition, a winch specification is also available without a brake valve and with a mechanical brake of external release pressure specification.

The following conditions are to be satisfied for the use of GM.

- GM should be used within the specification and the limitation specified by our corporation. (Specifications and the limitation should be in compliance with those in confirmation notice (that is equivalent to delivery specification sheet) for GM or the specifications and operating agreement on the machinery for which GM is used.)
  - If it is used beyond the limitation range, it may cause abnormal wear due to poor lubrication or may cause damage due to seizure.
  - If GM is operated continuously at a high temperature, or at high load or high rotation continuously, the life or performance decline and damage may occur.
  - GM is not intended for the use in a series circuit, and problems related to the use in a series circuit are not our responsibility.
- The product should be properly assembled in the customer's equipment. (Refer to P.14 in Chapter 4.)
- The proper lubrication condition should be maintained. (Refer to P.19 in Chapter 5.)
- The product should be installed in the environmental condition specified by our corporation. (Refer to P.10 on 3.1. in Chapter 3.)
- Make sure GMs of the same type are used when applying them facing each other or synchronizing.
  - To prevent damages of GM and the machinery, do not use GM of other type or other manufacturer's product.
- The following precautions should be observed:
  - When the end user is concerned with military or when the intended use is the manufacture of arms, the product may be regarded as an object of export regulation according to the Foreign Exchange and Foreign Trade Act in Japan. When exporting the product in this case, prepare review and necessary procedures.
  - Prepare an oil tray to prevent the lubricant from leakage due to malfunction or deterioration.

### 2. Precautions for Safe Use of GM

- Be sure to read this manual before use of GM.
  - NOTICE that this manual cannot cover all of the precautions related to safety. In transportation, installation and maintenance of GM, ensure to observe general safety precautions.
  - To prevent accidents, use the product only for the intended purpose. Avoid installation and maintenance work not specified or recommended in this manual.
  - Do not disassemble, repair, or modify the product, as it may cause malfunction or failure of the product. If disassembly or repair is necessary, contact our customer support.(Refer to P. 31)
  - Not only workers but also administrators should try to avoid any accidents.
  - The installation and maintenance of the product should be performed only by personnel with at least basic knowledge of the hydraulic motor and reduction gears and who have fully read and understood this manual.
-

- Use of GM out of the intended use or without understanding the contents of this manual may cause the following hazard:
  - Hazard to life and health of the user
  - Breakage of GM or the machinery incorporating GM
- Wear hand protection such as leather gloves, prior to the handling because there is a risk of injury due to edges of the product that are not intended for manufacturing.

### **3. Notice on the Operation Manual**

- This manual is intended for workers who are fluent in English. If this product is going to be operated or serviced by workers who are not fluent in English, the responsibility falls on the customer to provide thorough training on operation and safety.
- Ensure to operate the product according to the procedure and precautions specified and recommended in this manual. Any operation neglecting the described specification or recommendation may cause accidents and/or damage.
- This manual is copyrighted and all rights are reserved by our corporation. Any part of the drawings and technical references including in this manual shall not be copied, photocopied, or reproduced to any electronic medium or machine-readable form without prior consent of our corporation.
- The photographs and drawings described in this manual may not represent actual products strictly.
- If this manual is lost or damaged, immediately contact our customer support. Operating or servicing the product without this manual may result in accident.
- If you are going to transfer the product or machinery (attached or assembled in any way) to another party, be sure to submit this manual and related document to the new user.
- Reflect at least the description on lubricant (Chapter 5) and maintenance & inspection (Chapter 6) in this document to the operation manual for the customer machine into which GM is incorporated.

### **4. Disposal of GM**

Disposal of GM and packaging materials may be regulated by laws and regulations in each country / region. In addition, recyclable materials are required to be reused.

When disposing, ask an industrial waste disposal contractor and follow these regulations.

If there is anything uncertain, please contact our customer support for processing.

### **5. Other Important Notice**

- It is prohibited to analyze and use the product by any measure of reverse engineering or other related technology.
-

## Chapter 1 SAFETY

The safety precautions are to be guidelines to avoid human accidents during the transportation, installation, and maintenance of GM, as well as to avoid damage to GM.

### 1.1. Strict observance and Prohibition

Overall precautions are classified into strict observance and prohibition.

For precautions at installation and maintenance, be sure to refer to the description of the corresponding chapter.

#### ● **Strict observance**



- The transportation, installation, and maintenance should be performed only by personnel who understand the manual.
- The tools required for the work should be cleaned up to a specified place after work. Mixing a foreign object such as tools, screws and/or nuts may cause damage to the product.
- For handling of the hydraulic oil and the lubricant, refer to the indications and recommendations in this manual.

#### ● **Prohibition**

- The work coordinator and/or administrator should not let personnel who have no ample knowledge of the product. It may result in an injury to the operator or damage to the product.
  - Do not put fingers or any foreign object at the opening end of the product. It may result in serious or moderate injury.
  - Do not modify or disassemble the product. It may result in breakage of the product.
  - Do not apply excessive impact or vibration to the product. It may cause breakage of the product.
  - The product may be very hot during operation. After the operation, do not touch the product until it has cooled down. Otherwise it may result in a heat-related injury.
  - Do not perform rapid cooling for high-temperature GM. When cooling, perform air cooling by atmospheric air.
  - Do not put any inflammable object around the product. It may result in fire.
  - If any abnormality or breakage should occur in the product, do not operate it until a proper countermeasure is prepared.
-

## 1.2. Types of Warnings and their Meanings

The following four types of warnings are used according to the expected hazards during operation and maintenance of the product. Neglecting such safety rules and warnings may cause accidents, resulting in serious injury and/or damage to this product.

Signal word	Meaning
 <b>DANGER</b>	Indicates an imminently hazardous situation which, if not avoided or prepared protection measures, will result in death or serious injury.
 <b>WARNING</b>	Indicates a potential hazardous situation which, if not avoided or prepared protection measures, could result in death or serious injury.
 <b>CAUTION</b>	Indicates a potential hazardous situation which, if not avoided or prepared protection measures, may result in minor or moderate injury.
<b>NOTICE</b>	Indicates a potential hazardous situation which, if not avoided or not prepared protection measures, may result in property damage.

## 1.3. Notation and Meaning of Important Information

Notation	Meaning
<b>NOTE</b>	Important matters or useful information for the GM operation, maintenance and inspection.

---

## Chapter 2 OVERVIEW OF GM

### 2.1. Name of Each Part

Here is an explanation of the name of each part.

# NOTE

The following drawings may not strictly represent the actual appearance of the product ordered.

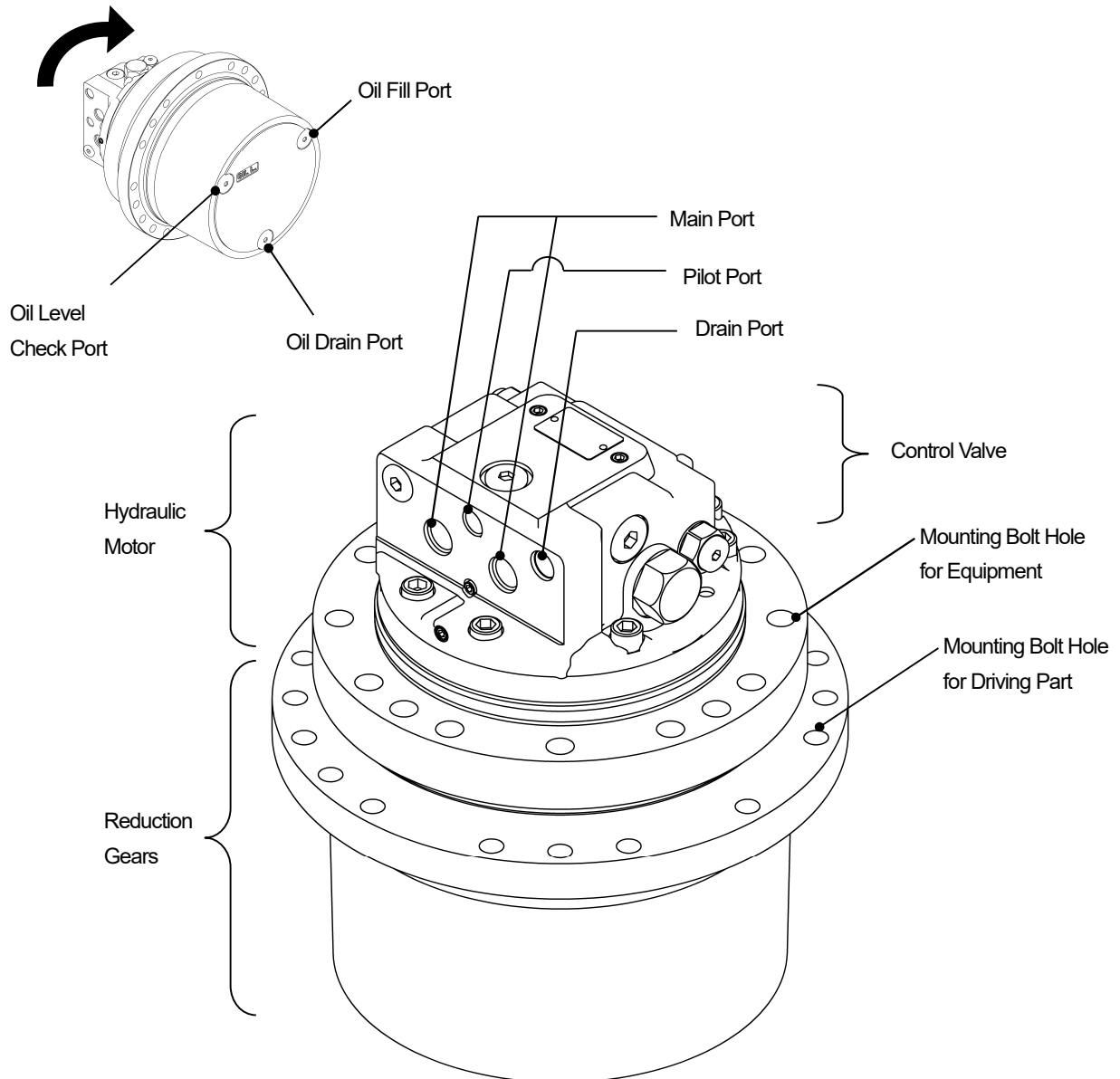

Fig. 2-1

## 2.2. Storage of GM

# NOTICE

---

**When storing the product, follow the same packing condition as before unpacking.**

**If the packaging conditions change, foreign matter may enter inside or rust may occur.**

---

To avoid rust, corrosion, and deterioration of seals, avoid storage in places such as:

- Places where the surrounding temperature is under  $-10^{\circ}\text{C}$  or over  $40^{\circ}\text{C}$  (Temperature recommended as the storage environment)
- Places of high humidity
- Places with direct sunlight
- Places where dew may condensate or freeze
- Outdoors with wind and rain directly
- Places near chemical substances such as an organic solvent, acid, and alkali
- Places exposed to corrosive gas and/or dust
- Places with unstable flooring
- Places where the floor strength is insufficient
- Places under vibration

# NOTE

---

**When the product is used or re-operated after a long-term, check the following:**

- **That there is no rust or corrosion;**  
**Although GM has antirust oil applied to the outside before shipping, check the antirust state at least once a year. Take an antirust measure as necessary. The antirust state before shipping will be maintained for approx. twelve month.**
  - **That seal parts has not been deteriorated over time.**
  - **That lubricant has not leaked.**
-

---

## Chapter 3 PREPARATION FOR INSTALLATION

### 3.1. Installation Environments



## WARNING

The installation environments should be in compliance with those specified in confirmation notice (that is equivalent to delivery specification sheet) for this product or the specifications and operating agreement on the machinery for which this product is used. Also, please do not use under the following environmental conditions. Using GM out of the specified environmental conditions may result in serious physical injury or fatal property damage.

- Places exposed to seawater or underwater
- Places exposed to toxic gases that may cause metal corrosion

### 3.2. Preparation of Necessary Materials

The installation of GM requires the following parts and materials.

Please prepare them after confirming the confirmation notice which includes installation drawing.

- **Mounting bolt**

The specifications and quantity of bolts required to mount GM are described in the confirmation notice. If there is anything uncertain, please contact our customer support.

- **Hydraulic oil**

A small amount of hydraulic oil remains in GM at the time of shipment. It remains in the process of shipping inspection and does not affect the performance of the product.

For detailed information on the hydraulic oil, refer to Chapter 5 (P.19) and the Safety Data sheet. For the Safety Data sheet, contact our customer support or the supplier of the hydraulic oil.

- **Lubricant**

GM is filled with the lubricant specified by our corporation at the factory.

For detailed information on the lubricant, refer to Chapter 5 (P.19) and the Safety Data sheet. For the Safety Data sheet, contact our customer support or the supplier of the lubricant.

---

### 3.3. Transportation and Unpacking

#### 3.3.1 Transportation



## WARNING

- The mass of GM is heavy. Be sure to use transportation equipment such as a forklift to transport GM units.
- In transporting GM, handle it with ample care to avoid drops or falls. Otherwise it may result in injuries of the operator or damage to GM.
- For the personnel who carry out transportation, at least observe the following condition and wear the protective gear.
  - A forklift must be operated by a qualified person.
  - Be sure to wear a helmet, leather gloves and protective footwear.
- Be sure to check that GM is in the correct vertical orientation before unpacking the package. If it is turned upside down, the packaging material may be damaged, and GM may jump out and cause injury to workers.

- **GM weight**

Refer to the confirmation notice.

---

### 3.3.2 Unpacking

## NOTICE

Since GM has antirust oil applied to the outside before shipping, it may be slippery.  
Wipe off the antirust oil before operation.

## NOTE

- The drawings in this manual do not necessarily represent the individual packaging or the product. They change by the individual product or the confirmation notice. Also, for convenience, the drawings are cut out of the packaging material so that the contents can be imaged.
- Reduction gears of GM is filled with lubricant specified by our corporation at the factory.
- When hoisting GM, refer to the Hoisting GM section (Sections 4.1 and 4.2 on P.14 and P.15).

[Packing example 1]

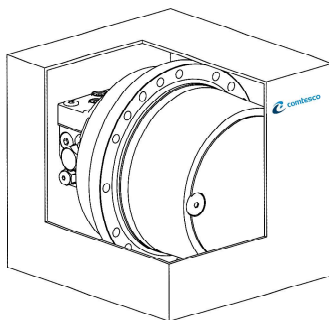

[Packing example 2]

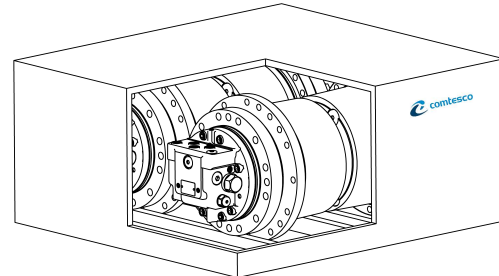

Fig. 3-1

- **Confirmation of contents**

Confirm the following before using the product:

Please contact our customer support if there is any delivery error or damage.

- The confirmation notice number matches the MS number on the nameplate, and the type code shown on the confirmation notice matches the type code shown on the nameplate. (Refer to nameplate contents P.13)
- There was no breakage during transportation. (Refer to the confirmation notice.)
- Check the confirmation notice and GM, there was no missing of the bolts by visual confirmation.

# NOTE

At the time of delivery, covers or plugs are attached to ports of the product to prevent contamination from entering inside. (They are not shown in the confirmation notice.) Do not remove it during storage, and remove it when connecting pipes.

- **Confirmation of lubricant**

Refer to Replacement procedure (P. 22) in Sections 5.5 Replacing Lubricant. And check that the lubricant is filled by using the oil level check port.

- **Labeling**

The nameplate is attached on the body of GM.

It indicates the product type, and others.

The type information includes the following product information.

<Nameplate example>

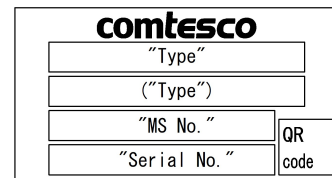

<Indication example of standard product type>

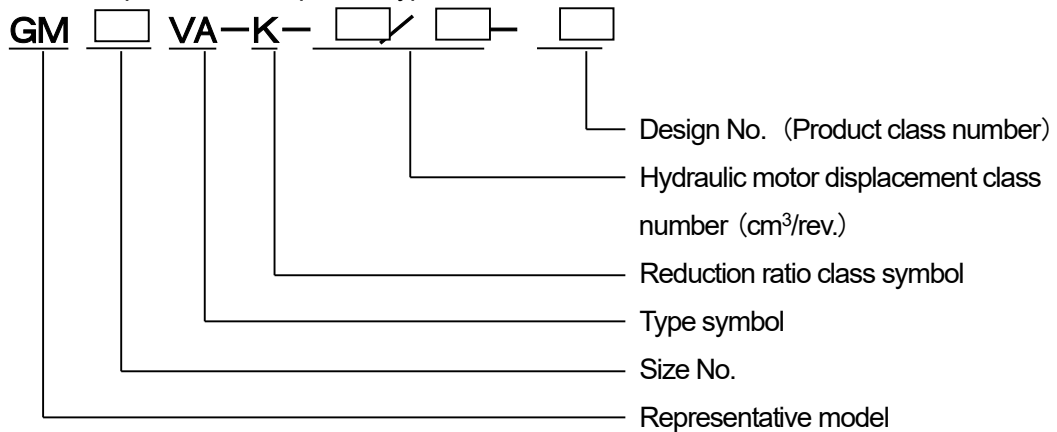

<Indication example of application product type>

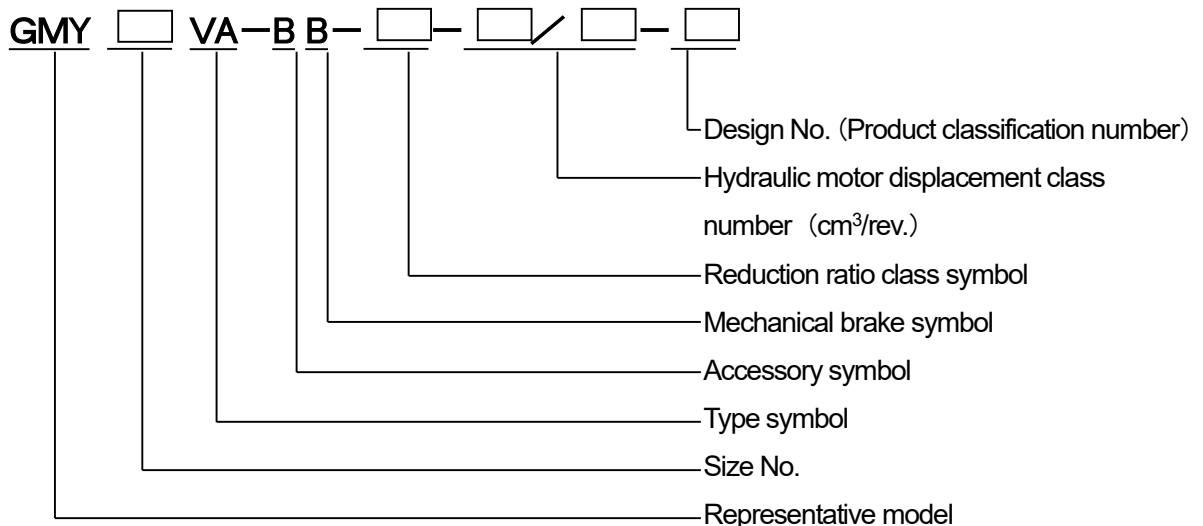

## Chapter 4      **INSTALLATION IN THE MACHINE**

### 4.1. Precautions on Hoisting



## **CAUTION**

- The crane operation during hoisting must be conducted by a qualified person.
- Be sure to wear a helmet, leather gloves and protective footwear during hoisting work.
- The mass of GM is heavy. Use a hoisting tool robust enough to endure the mass of GM. If the strength of the hoisting tool is insufficient, the tool may be damaged and/or drop GM.
- Never get under GM while it is being hoisted.



## **WARNING**

Hoist GM body horizontally in a balanced manner. If it loses its balance and falls, operators may be injured or the customer machine and GM may be damaged.

---

## 4.2. Hoisting and Installing GM

**Step 1** Attach the hoisting tool to GM.

**Step 2** Hoist GM body.

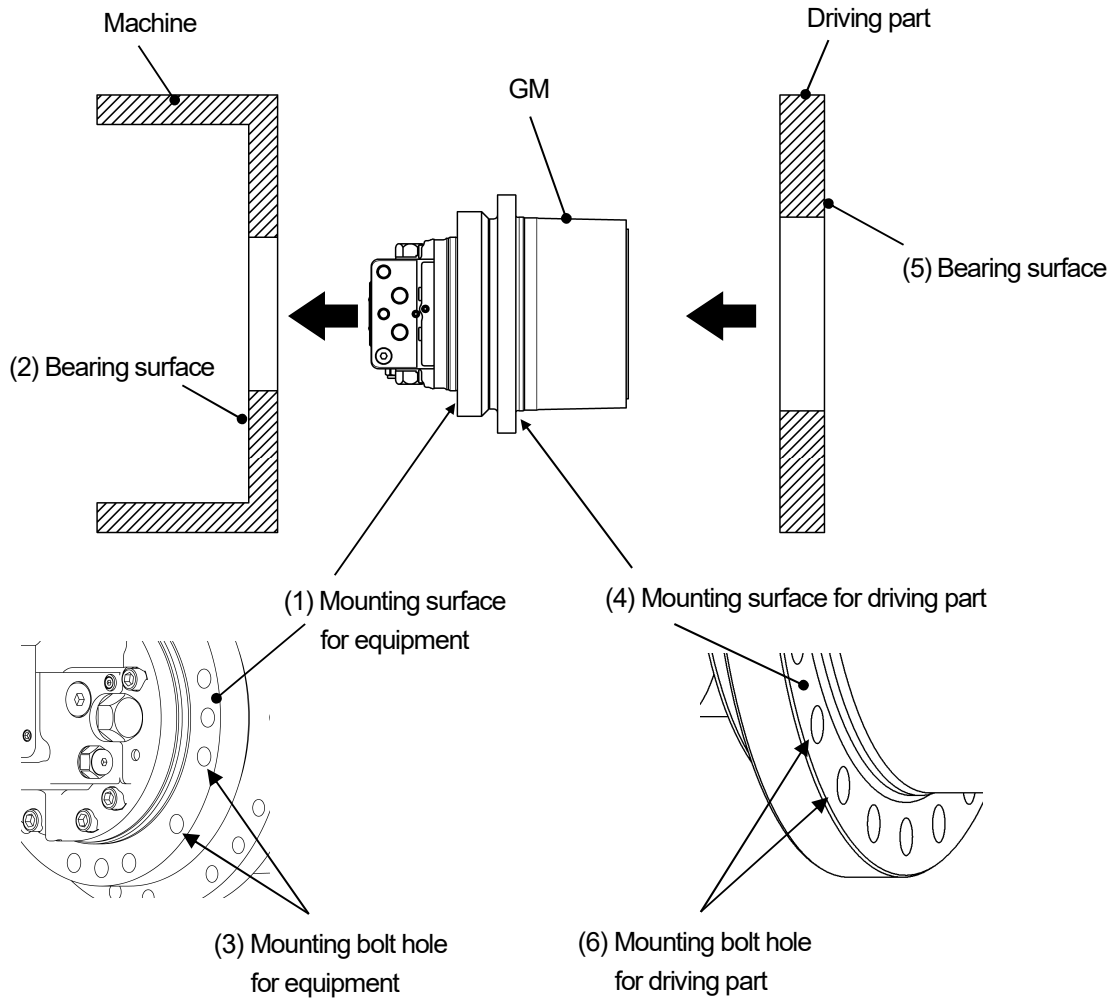

**Fig. 4-1**

**Step 3** Check that there are no burrs or dirt on (1) Mounting surface for equipment of GM and GM mounting surface of the Machine, and wipe off the antirust oil on (1) Mounting surface for equipment of GM and (2) Bearing surface of the machinery.

## NOTE

**GM has antirust oil applied to the non-painted surfaces before shipping. To keep the transmitting torque by bolts high, wipe off the antirust oil on the mounting surface sufficiently.**

- Step 4** Align (3) Mounting bolt hole for equipment of GM with the mounting holes of the machinery, and assemble GM into the machinery.

## NOTE

---

**During the installation, do not hit GM with a hammer and the like.**

---

- Step 5** Insert the flat washers and the mounting bolts into (3) Mounting bolt hole for equipment of GM.

## NOTICE

---

**Use the specified number of GM mounting bolts and tighten with the specified tightening torque. Otherwise, not only GM may not provide its performance but also the customer machine and GM may be damaged.**

---

- Step 6** Tighten the mounting bolts for equipment uniformly with the specified tightening torque. Refer to the confirmation notice for the quantity and bolt size.

**Table 4-1 Bolt tightening torque**

Bolt size	M12(P1.75)	M14(P2.0)	M16(P2.0)	M20(P2.5)	M24(P3.0)
Tightening torque [N·m] (Recommendation)	102±15.7	163±24.5	252±39.2	493±78.5	709±88.3

- Step 7** Check that there are no burrs or dirt on (4) Mounting surface for driving part of GM and GM mounting surface of the Driving part, and wipe off the antirust oil on (4) Mounting surface for driving part of GM and (5) Bearing surface of the Driving part.

## NOTE

---

**GM has antirust oil applied to the non-painted surfaces before shipping. To keep the transmitting torque by bolts high, wipe off the antirust oil on the mounting surface sufficiently.**

---

- Step 8** Align (6) Mounting bolt hole for driving part of GM with the mounting holes of the Driving part, and assemble the Driving part into GM.

## NOTICE

---

**During the installation, do not hit GM with a hammer and the like.**

---

- Step 9** Insert the flat washers and the mounting bolt for driving part into (6) Mounting bolt hole for driving part of GM.
-

## NOTICE

---

Use the specified number of GM mounting bolts and tighten with the specified tightening torque. Otherwise, not only GM may not provide its performance but also the customer machine and GM may be damaged.

---

**Step 10** Tighten the driving part mounting bolts uniformly with the specified tightening torque. (Refer to Table 4-1 on P.16) Refer to the confirmation notice for the quantity and size of bolts.

### 4.3. Hydraulic Piping Connection

After installing GM, connect hydraulic piping.

**Step 1** Remove the covers or plugs attached to the port.

**Step 2** Fill the motor casing with hydraulic oil. Refer to the confirmation notice for the amount of hydraulic oil.

## NOTICE

---

Fill the motor casing with hydraulic oil before use. If GM is operated without supplying hydraulic oil, the product may be damaged.

---

**Step 3** Connect each hydraulic pipe.

## NOTICE

---

- Confirm GM piping port, rotation direction, and piping size in the confirmation notice.
  - Select the piping size so that the drain port back pressure is below the pressure described in the confirmation notice.
- 

### 4.4. Trial Run after Installation

After installing GM on the customer machine equipment and piping it, check that the rotating direction is the intended direction. Also, follow the note below and operate safely after running-in GM.

## NOTE

---

In the running-in operation, use the engine of the equipment in low idling and keep idling for 5 minutes or more to remove the inside air with GM at 1st speed.

---



## CAUTION

- Never approach the rotating part during machine operation. Person(s) may be caught by the rotating part, causing fatal accidents.
- GM may become hot during operation. After stopping the operation, do not touch GM until it has cooled down.
- Immediately stop operation when any abnormality occurs. Continuous operation may cause injuries to the operator.
- Observe GM specifications and the limitation of specifications specified by us.  
(Specifications and the limitation should be in compliance with the confirmation notice for GM or the specifications and operating agreement for the machine for which GM is used.)

## NOTICE

---

Do not perform rapid cooling for high-temperature GM. When cooling, perform air cooling by atmospheric air.

---

## Chapter 5 HYDRAULIC OIL AND LUBRICANT

This chapter describes hydraulic oil and lubricant. The description on hydraulic oil and lubricant (this chapter) in this document should be reflected at least to the operation manual for the customer machine into which GM is incorporated.

### CAUTION

- When replacing the hydraulic oil and lubricant, turn off the power to the customer machine.
- GM may become hot during operation. After stopping the operation, do not touch GM until it has cooled down. If the oil filler port and oil drain port are unplugged in the high-temperature state, the high-temperature lubricant may blow out accidentally due to the pressure change in the reduction gears, which can cause burn injury.

### NOTICE

---

- GM is filled with the lubricant at the factory. Filling up the lubricant excessively may result in heat generation and leakage of the lubricant.
  - GM is drained hydraulic oil at the time of shipment. Be sure to fill the motor casing with hydraulic oil before operation.
  - If the amount of the lubricant has decreased due to some reason, identify and remove the cause, and then add the lubricant.
  - When draining the lubricant, do not drain it on the ground. Be sure to drain it into a container. Disposal of the waste oil should be in accordance with the applicable laws and regulations.
  - Do not perform rapid cooling for high-temperature GM. When cooling, perform air cooling by atmospheric air.
- 

#### 5.1. Precautions when Handling Hydraulic Oil and Lubricant

- **Precautions when handling hydraulic oil and lubricant are as follows:**
    - Before handling hydraulic oil and lubricant, be sure to read the precautions described on the case/bottle of each lubricant for correct use. Wrong usage may cause fatal accident.
    - Be sure to wear protective goggles in order to prevent hydraulic oil and lubricant from entering into eyes.
    - Be sure to wear rubber gloves to prevent hydraulic oil and lubricant from contacting your skin.
    - Do not eat or put hydraulic oil and lubricant into your mouth.
    - For detailed information, refer to Safety Data Sheet of hydraulic oil and lubricant. Ask to the Safety Data Sheet from our Customer Support or the purchaser of hydraulic oil and lubricant.
-

● **Emergency measure:**

- If hydraulic oil or lubricant comes into contact with eyes, flush for 15 minutes with clean water and seek medical treatment.
- If hydraulic oil or lubricant comes into contact with skin, wash affected area with water and soap.
- If hydraulic oil or lubricant is swallowed, do not induce vomiting and seek medical treatment immediately.

● **Disposal of waste oil and container:**

- Proper disposal is required by laws and regulations. Follow the laws and regulations.
- Consult the purchaser of hydraulic oil and lubricant for assistance or advice if any uncertainty arises.

● **Storage**

- To avoid any foreign object or water from being mixed in, seal container of hydraulic oil and the lubricant after use.
- Avoid direct sun light, keep away from fire or heat sources, and store in a cool and dark place.

**5.2. Type of Hydraulic Oil**

## NOTICE

**Use the hydraulic oil recommended by us. Use of any other hydraulic oil may degrade the performance and durability of GM.**

● **Hydraulic oil specified by Comtesco**

- Use a wear-resistant hydraulic oil with a viscosity equivalent to ISO VG32 to VG46.
- The cleanliness of hydraulic oil should be maintained within level NAS9.
- The recommended brands are as follows.

Grade	Viscosity (40 [°C])	32 [mm <sup>2</sup> /s]	46 [mm <sup>2</sup> /s]
	JIS	VG32	VG46
Manufacturer name	Idemitsu Kosan	Daphne Super Hydro A32	Daphne Super Hydro A46
	Exxon Mobil	Mobil DTE24	Mobil DTE25
	ENEOS	SUPER HYRANDO 32	SUPER HYRANDO 46
	Cosmo Oil	Cosmo Hydro AW32	Cosmo Hydro AW46

- **Filling volume of hydraulic oil**

Prepare hydraulic oil according to the amount of hydraulic oil described in the confirmation notice.

- **Temperature and viscosity range of hydraulic oil**

Make sure that the operating temperature range and viscosity range of the hydraulic oil do not exceed the following ranges.

- Operating temperature range : -20~+90 [°C]
- Practical viscosity range : 15~500 [mm<sup>2</sup>/s]

## NOTICE

**When using with a viscosity of 500 [mm<sup>2</sup> / s] or more, the motor may not be able to suck oil and may cause malfunction. In addition, if the viscosity is less than 15 [mm<sup>2</sup> / s], the performance will decrease significantly, and if it is used for a long time, the motor sliding part may get damaged, resulting in a permanent deterioration in performance.**

### 5.3. Replacing Hydraulic Oil

- **Replacement interval**

- Replace with new oil every 1000 engine hours or 1 year.
- If the deterioration of the hydraulic oil is severe even within the above replacement interval, replace it according to the following standard.

Test items		Replacement criteria
Viscosity change (40[°C])	[mm <sup>2</sup> /s]	Within ±10[%]
Total oxidation	[mgKOH/g]	Consult with the hydraulic oil manufacturer because it depends on the oil type and manufacturer.
Water content	[%]	Within 0.1
Impurities	[mg/100mL]	Within 10
Insoluble content	[%]	Within 0.05
Color	—	Drastic change

- **Replacement procedure**

Replace and replenish according to hydraulic oil replacement and replenishment procedure of the machine.

---

## NOTICE

---

Use the same hydraulic oil brand for replacement and replenishment, and do not mix different brands.

---

### 5.4. Type of Lubricant and Filling volume

---

## NOTICE

---

Use the lubricant recommended by us. Use of any other lubricant may degrade the performance and durability of GM.

---

- **Lubricant specified by Comtesco**

Use a lubricant with extreme-pressure additive equipment to SAE # 90 (API class GL-4 or higher).The following brands are recommended.

Manufacturer name	Product name
ENEOS	Gear Oil GL-4 90
Idemitsu Kosan	Apolloil Gear HE90
Exxon Mobil	Mobilube HD80W-90
Shell	Shell Spirax EP90
Cosmo Oil	Cosmo Gear GL-4 90

- **Filling volume lubricant**

Prepare lubricant according to the amount of lubricant in the confirmation notice.

- **Temperature range of lubricant**

Operating temperature range : -20 ~+80 [°C]

### 5.5. Replacing Lubricant

- **Replacement interval**

- Replace with new oil at 500 engine hours first, after that every 1000 engine hours. Replace the lubricant if it has been in stock for a long time (1 year or more).
-

- If the lubricant deteriorates severely even within the above replacement interval, replace it according to the following standard.

		Replacement	Apply
Viscosity change (40°C)	[mm <sup>2</sup> /s]	Within 10% compared with new oil	Progress of oxidative degradation Mixing of different oils
Water content	[%]	Within 0.2	External contamination
Pentane insoluble matter	[%]	Within 1.0	Oxide, carbon, additives, wear powder, dust, and so on. from outside
Total oxidation	[mgKOH/g]	0.5 increase compared with new oil	Progress of oxidative degradation
Metal analysis	Al	[ppm]	Within 150
	Cr	[ppm]	Within 20
	Cu	[ppm]	Within 20
	Fe	[ppm]	Within 600
	Si	[ppm]	Within 350

- **Replacement procedure**

## CAUTION

- Confirm that the power of the customer machine is turned off before beginning the replacement work.
- Immediately after operation, GM and lubricant may be hot and may cause burns if touched. Work after the temperature has dropped sufficiently.
- Lubricant may eject when removing the reduction gears plug to supply and drain oil. Please work with great care, such as slowly removing the plug to relieve internal pressure.
- Be sure to wear protective goggles and rubber gloves.
- Do not replace/replenish the lubricant in a subfreezing environment. Failure to observe this may result in cold injury. Also, if the lubricant is replaced/replenished in a subfreezing environment, the temperature difference from the operating temperature increases and the pressure increase in the reduction gears may cause oil leakage.

## NOTICE

---

Do not perform rapid cooling for high-temperature GM. When cooling, perform air cooling by atmospheric air.

---

# NOTICE

---

**Use the same lubricant brand for replacement and replenishment, and do not mix different brands.  
When changing the oil type, flush the inside of reduction gears.**

---

Replace or replenish the lubricant according to the following procedure. Also, work with GM in the posture with the Oil Fill Port up and the Oil Drain Port down as shown below.

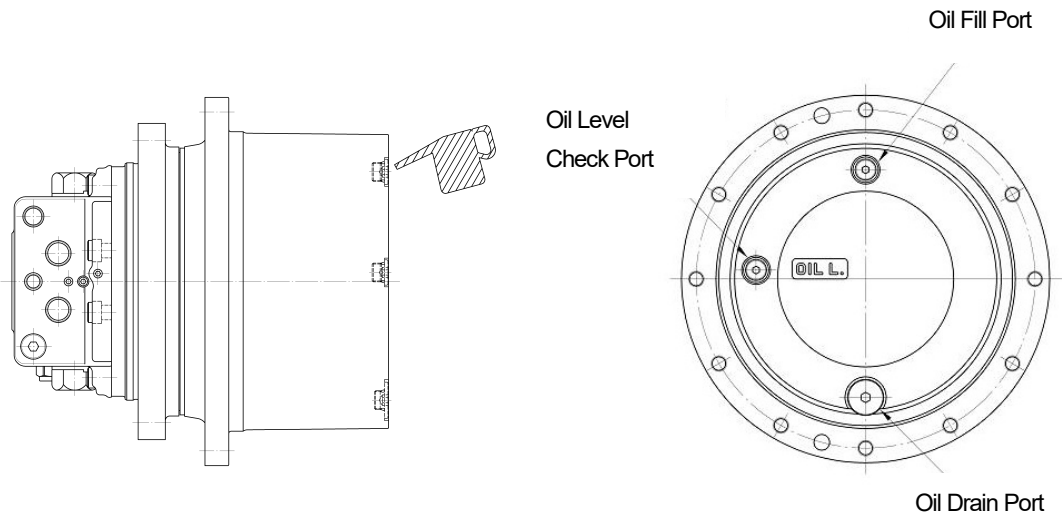

**Fig. 5-1**

**Step 1** When replacing, remove the plug of the Oil Fill Port, Oil Drain Port, and Oil Level Check Port, and drain the lubricant. When replenishing the lubricant, do not remove the plug of the Oil Drain Port.

# NOTICE

- 
- **Receive the drained lubricant with a container.**
  - **If there is sealing tape on the tapered screw hole after removing the plug, remove it completely.**
- 

**Step 2** After the completion of drainage, plug the Oil Drain Port, and tighten the plug with the specified tightening torque (P.25 Table 5-3).  
(Refer to the confirmation notice for plug size.)  
Fill up the lubricant from the Oil Fill Port.

**Step 3** Referring to the amount of filled lubricant described in the confirmation notice.  
(The Oil Level Check Port is a reference for oil level.)

---

---

## NOTE

---

If the lubricant is filled up excessively, the inner pressure increases, which can cause a leakage of the lubricant or damage to the oil seal.

When the lubricant is small in amount, insufficient lubrication may cause damage to GM.

---

**Step 4** When filling is complete, insert the plug into the Oil Fill Port and Oil Level Check Port, and tighten with the specified tightening torque. (Refer to the confirmation notice for the plug size.)

**Table 5-3** Plug size and tightening torque

Size	G3/8	G1/2	G3/4	R3/4
Tightening torque[N-m]	58.8±9.81	98.1±19.6	147±14.7	98.1±19.6

---

## NOTICE

---

- When tightening the plug with O-ring to each port, make sure that the O-ring is not damaged.
  - After checking that the R plug is clean, wrap it properly with new sealing tape and then assemble it.
- 

**Step 5** If the lubricant has adhered to the periphery, wipe it off sufficiently.

---

## Chapter 6 MAINTENANCE & INSPECTION

This chapter describes the maintenance and inspection. Reflect at least the description on maintenance & inspection (this chapter) in this document to the operation manual for the customer machine into which GM is incorporated.

### 6.1. Precautions on maintenance and inspection

#### CAUTION

- Turn off the power to the customer machine before starting maintenance and inspection. If maintenance or inspection is performed during machine operation, person(s) may get burned due to high temperature or be caught by the rotating part, causing fatal accidents.
- Do not perform maintenance and inspection in a subfreezing environment. Failure to observe this may result in cold injury. Also, if maintenance or inspection is performed in a subfreezing environment, the temperature difference from the operating temperature increases and, as the result, the increased pressure in the reduction gears may cause oil leakage.
- GM may become hot during operation. After stopping the operation, do not touch GM until it has cooled down.
- Wear appropriate clothing and appropriate protective equipment (protective goggles, protective gloves, and protective footwear).
- Abnormal noise should be checked during operation. Never touch the machine during the check.

## NOTICE

Do not perform rapid cooling for high-temperature GM. When cooling, perform air cooling by atmospheric air.

### 6.2. Periodical Inspection

#### ● Periodical inspection list

Inspect the following items at least once in a year.

Lubricant must be replaced based on the operating time. Refer to Section 5.5 Replacing Lubricant (P.22) and replace as appropriate. For hydraulic oil, replace it appropriately referring to Section 5.3 Replacing Hydraulic Oil (P.21).

No.	Inspection item	Description	Reference
1	Leakage of lubricant	Check whether there is not a leakage of lubricant from the mating surface around GM and floating seal section.	6.2.1.
2	Bolt looseness	Check whether each mounting bolt is not loose.	6.2.2.
3	Abnormal noise	Check whether there is not any abnormal noise or sudden change in sound.	6.2.3.
4	Surface temperature of GM	Check whether surface temperature of GM is abnormally high.	6.2.4.

## ● Necessary tools

The typical tools required for maintenance and inspection are listed below.

- Hexagon wrench
- Wrench
- Torque wrench
- Surface thermometer

### 6.2.1. Checking for lubricant leakage

Visually check the periphery of the reduction gears, joint surface with the machine, and the entire machine to make sure that there is no leakage of the lubricant.

If a leakage of the lubricant has been found, identify and remove the cause, and then replenish the lubricant.

## NOTICE

---

**The adhering dirt and sand may cause seizure, heat generation, or protrusion, and the lubricant may leak due to the loss of the sealing performance of the floating seal.**

---

### 6.2.2. Inspecting the mounting bolts

Check looseness of the mounting bolts for equipment and the mounting bolts for driving part. If any are loose, retighten with the specified tightening torque. (Refer to P.16 Table 4-1 for the tightening torque.)

### 6.2.3. Checking for abnormal noise

 **CAUTION**

Abnormal noise should be checked during operation. Never touch the machine during the check.

**Step 1** Be careful not to touch GM and check abnormal noise or sudden changes in sound.

**Step 2** If any abnormal noise has been detected, report it to the administrator and stop the machine operation.

### 6.2.4. Inspecting the surface temperature

Measure the surface temperatures of the motor and reduction gears to check whether they are not over the standard temperature. Perform the measurement after continuous operation.

---

**Step 1** Using a surface thermometer, measure the surface temperature at the measurement point shown in the following figure below and the surrounding area to check the maximum value.

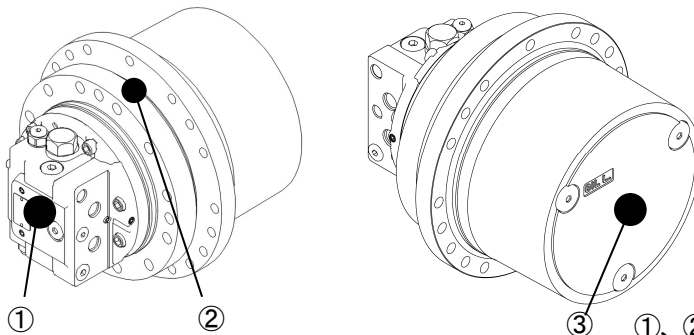

Fig. 6-1

①、② : Hydraulic motor temperature measurement point

※② anywhere on the circumference

③ : Reduction gears temperature measurement point

## NOTE

For the method of using the surface thermometer, refer to the operation manual attached to the product you use.

**Step 2** If the surface temperature is more than 80°C, report it to the administrator and stop the machine operation.

Standard surface temperature of hydraulic motor and reduction gears in continuous operation :  
Maximum 80°C

### 6.3. Removal from the Machine

If it is necessary to remove GM from the machine for maintenance, inspection, or replacement, pay the following precautions and remove it in the reverse procedure described in Section 4.2 Hoisting and Installing GM (refer P.15).



## CAUTION

- To remove GM, hoisting by crane operation is needed. Before starting the removal, refer to “4.1 Precautions on Hoisting” (P.14) to confirm the precautions on hoisting and work procedure. Hoist GM in accordance with the description.
- Make sure no torque remains on GM before starting work.

## Chapter 7 TROUBLESHOOTING

If there is any problematic phenomenon, check the cause and take measures according to the following table.

If the measure marked with a circle is needed, stop the machine operation and contact our customer support.

For the item marked with a circle, contact our customer support.

Phenomenon 1	Phenomenon 2	Possible cause	Countermeasure		
Does not rotate	No pressure is applied	Low set pressure of the relief valve	Set the pressure correctly.		
		Malfunction of the pump	Repair.		
		Malfunction of the direction-switching valve	Repair.		
	Pressure is applied		Malfunction of the brake valve	Replace or repair the brake valve.	○
			Malfunction of the hydraulic motor	Repair.	○
			Damage of the gears (reduction gears)	Replace GM.	○
			Overloaded	Remove the load.	
Oil leakage	From the mating surfaces	Scratches on mating surfaces	Polish the surface using a grindstone, polishing paper, and so on.	○	
		Looseness of bolts	Retighten the bolts.		
	From the case	Looseness of plugs	Retighten the plugs.		
		Cracks with stones	Replace GM.	○	
	From the floating seal	Intrusion of earth and sand	Wash away the earth and sand from the floating seal.		
		Wear of sliding surfaces	Replace GM.	○	
		O-ring creep	Replace GM.	○	
	From the hydraulic motor	Looseness of bolts	Retighten the bolts.		
		O-ring damage	Replace the O-rings.	○	
		Scratches on the sealing surface	Polish the surface using a grindstone, polishing paper, and so on.	○	
Rotated by load during use	Increased internal or external drain	Reduced volumetric efficiency of the hydraulic motor	Replace GM.	○	
		Increased internal leakage (drain) of the brake valve	Replace or repair the brake valve.	○	
	Parking brake is not working	Damage to springs	Replace the springs.	○	
		Friction plate wear	Replace the friction plate and the mating plate.	○	
		Blockage of the oil passage by contaminants	Replace or repair the brake valve.	○	

Phenomenon 1	Phenomenon 2	Possible cause	Countermeasure	
The surface temperature of the reduction gears is high		Lack of lubricants	Replenish to proper amount.	
		Pitting occurs in bearings and gears	Replace GM.	○
		Hydraulic oil enters the gear case	Replace the oil seal and lubricants.	○
Meander (when used as a travel motor)	Occurring at low pressure	The left and right discharge oils are different	Repair the pump.	
		The left and right hydraulic motor drains are different	Replace GM.	○
	Occurring at high pressure	The left and right discharge oils are different	Repair the pump or the control valve.	
		The left and right hydraulic motor drains are different	Replace GM.	○
		The left and right brake valves movement are different	Replace the brake valve.	○
Relief pressure drop on either side of the control valve	Correct set pressure./ Replace the relief valve.			
Speed is insufficient	Low pump discharge	Pump does not work properly	Replace or repair the pump.	
		Excessive pump leakage	Replace or repair the pump.	
			Large amount of leakage from the hydraulic motor	Replace GM.
Abnormal noise is produced	From GM	Damage to the hydraulic motor or reduction gears	Replace GM.	○
	From the pipe	Vibration of pipes	Clamp the pipes.	
Do not switch from low speed to high speed		malfunction of the high pressure selection check valve	Replace the control valve	○
		malfunction of the switching valve	Replace the 2-speed spool.	○
		Low pilot pressure	Set to the specified pressure	
		malfunction of the 2-speed switching piston	Replace GM.	○
		Blockage of the passage at the 2-speed choke	Replace GM.	○
Do not switch from high speed to low speed		malfunction of the switching valve	Replace the 2-speed spool.	○
		malfunction of the 2-speed switching piston	Replace GM.	○

## CUSTOMER SUPPORT

For inquiries related to products and servicing, please contact customer support (see the following addresses):

For inquiries, be ready to provide the product information described on the nameplate attached on the product.



## Comtesco Corporation

### Tokyo Branch

#### Sales

7-9 2-chome, Hirakawa-cho,  
Chiyoda-ku, Tokyo 102-0093, Japan  
Telephone: +81-3-5213-1152  
E-mail: CMTJ\_Contact@comtesco.com  
HOMEPAGE [www.comtesco.com](http://www.comtesco.com)

### Sales Representatives

When contacted by a sales representative;

(Name and address here)