

Control Valve Operation Manual

NSC10 Type Manual Control Valve

*For the applicable models, please refer to the “part number” on the shipping label.

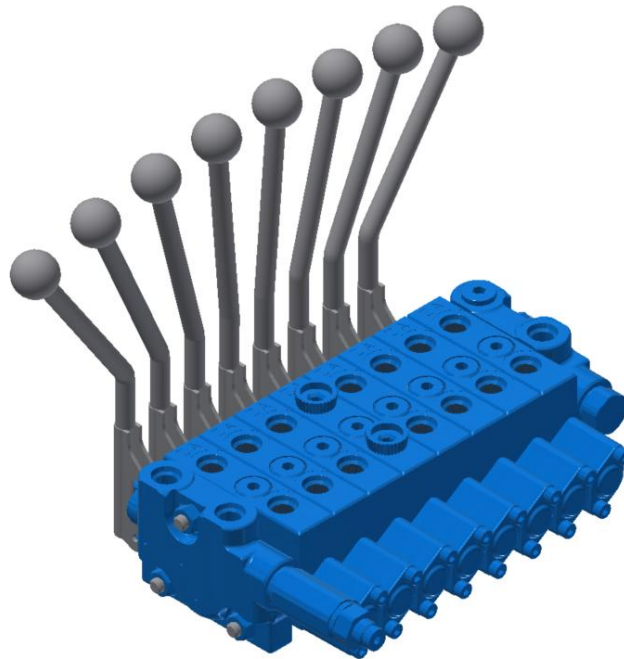

You must read this manual carefully and use the product after fully understanding the contents.

We request you to give this Operation Manual to the supervisor and the operator.

Please keep this manual in a safe place so that you can refer to it whenever necessary.



A JV OF COMER INDUSTRIES AND NABTESCO

©Comtesco Corporation All Rights Reserved.

Introduction

Thank you for purchasing the control valve (henceforth referred to as “the product”) made by Comtesco Corporation (referred to as “our company”).

This Operation Manual (referred to as “this manual”) covers the following matters, intended for the workers engaged in carrying, storage, installation, operation, maintenance, inspection, removal and disposal of the product.

- Precautions for safe carrying, storage, installation, operation, maintenance, inspection, removal and disposal of the product
- Information about proper carrying, storage, installation, operation, maintenance, inspection, removal and disposal of the product

When further reading this manual, you have to also prepare the specification drawing that also serves as assembly drawing provided separately (henceforth referred to as “specification drawing and assembly drawing”). This manual may require that you refer to the dimensional outline drawing described in the specification drawing and assembly drawing. In addition to this manual, the specification drawing and assembly drawing are also necessary when you handle the product.

Structure of the Operation Manual

This manual contains the following chapters.

Contained Chapters	Description
Important Notes	Describe: 1 Intended Use of the Product 2 Precautions for Safe Use of the Product 3 Provision of Danger Information to Users 4 Disposal of the Product 5 Others
About This Manual	The target audience and copyright of this manual
Warranty	The warranty for the product
Terms and Definitions	The terms related to the product
Table of Contents	The table of contents for this manual
Chapter 1 Safety	The safety precautions regarding the handling of the product
Chapter 2 Overview of the Product	The overview of the product and the names of the parts
Chapter 3 Specifications	The use environment and specifications of the product
Chapter 4 Unpacking	The precautions for the product unpacking and the parts to be included
Chapter 5 Carrying and Storage	The precautions for carrying and storage of the product
Chapter 6 Installation Preparation	The precautions to take before installation and the components to be prepared
Chapter 7 Installation	The precautions for installation of the product, how to install it in a machine, and the procedures for installing the piping and the control lever
Chapter 8 Operation	The precautions for operation and the checking procedures
Chapter 9 Maintenance and Inspection	The precautions and inspection items for the product maintenance and inspection, and the lubricant replacement
Chapter 10 Removal and Disposal	How to remove the product from the machine and dispose of it
Chapter 11 Troubleshooting	How to handle a problem
Customer Service	The customer service of our company

Important Notes

1 Intended Use of the Product (Purpose of Use)

The product is designed and manufactured as a device that distributes hydraulic fluid coming from the hydraulic pump to hydraulic actuators (referred to as “actuators”) connected to the product to operate each of them manually.

You are not permitted to use it for any other purpose.

2 Precautions for Safe Use of the Product

Our company cannot foresee all the product’s residual potential hazards, and hazards resulting from human error and peripheral equipment.

Furthermore, though there are many items to be observed and prohibited when you work with the product, all of them cannot be covered in this manual. Therefore, when working with the product, you have to take necessary safety measures, in addition to the precautions described in this manual.

The matters below show the ones thought to be especially important for safe handling of the product. They apply to all workers, including the manager and supervisor of the product. The term “work” in this manual refers to all activities related to the product, such as transportation, installation, operation, maintenance, inspection, removal and disposal.

Read This Manual Before Use

Before using the product, you have to carefully read this manual and fully understand its contents. You must also observe the safety precautions described in this manual.

Requirements for Workers

The workers who handle the product must meet all of the following conditions that they:

- have basic knowledge of the product handling.
- understand the hazards of the product and how to avoid them.
- have the ability to implement measures to avoid risks.

Compliance with laws, regulations, agreements and rules

The workers must comply with all the applicable laws, regulations, agreements and rules in the country and the region.

Prevention of accidents

To prevent an accident, you must observe the following points.

- Doing anything not included in this manual is prohibited to prevent an accident. You are also required not to use the product for any purpose other than the intended one described above.
- If an abnormal condition occurs, you must take safety measures by stopping the drive, conducting a safety inspection, and so forth, depending on the abnormality. Prompt measures can help prevent serious accidents and unnecessary wear and tears.
- Not only the workers but also everyone, including the supervisor, should proactively take part in the activities that ensure safety and health. Doing so will help prevent accidents.

3 Provision of Danger Information to Users

If you sell or give away the equipment where the product is incorporated (referred to as “machine”), you have to observe the following instructions.

- You should give this manual to the person (or the group) who actually uses or manages the machine. Or, you should reflect the handling and maintenance information necessary for prevention of accidents and failures in the operation manual of the machine.

4 Disposal of the Product

The disposal of the product and its packing materials is largely regulated by national and regional regulations and ordinances. Recyclable materials have to be reused.

You have to ask an industrial waste disposal company to dispose of them in accordance with these regulations.

If you have any questions, please contact our customer service.

5 Others

We prohibit analysis and use of the internal parts of the product by means of reverse engineering.

About This Manual

1 Target Audience

This manual is intended for the workers who meet the following two conditions. If you have other persons handle the product, you are responsible for providing thorough safety education and operation guidance to the workers.

- Those who speak the language used in this manual as their native language, or who can understand the language as well as their native language.
- Persons who meet the work requirements described in “2. Precautions for Safe Use of the Product” of “Important Notes.”

2 Contents of This Manual

The product and the contents of this manual are subject to change without notice.

3 Loss or Damage of/to This Manual

If this manual is lost, torn or damaged, please order it from us promptly. Handling the product without this manual can cause an accident.

4 Publishing on the Website

The PDF version of this manual can be downloaded from the following website.

www.comtesco.com

If the published information needs additions and corrections, the PDF version may be updated in advance.

5 Copyright

The copyright of this manual belongs to our company. Unauthorized reprinting, duplication, copying or translation of any part or all of this manual is strictly prohibited.

6 Trademark

Comtesco is the registered trademark of our company.

Warranty

- 1 If, during the warranty period of the product (one year after delivery to the customer), we confirm that the product is malfunctioning due to a design or manufacturing defect, we will repair it or provide a replacement at our expense at our discretion.
- 2 The scope of the warranty for the product is limited to the repair of the failure or the delivery of a substitute described in the preceding paragraph, without covering any compensation for other expenses.
- 3 If any of the following conditions apply, the failure of the product is not covered by the above warranty and is dealt with for a fee.
 - (1) If failure was caused by usage outside the operating conditions specified by us or outside the range specified by the specification drawing and assembly drawing.
 - (2) If failure was caused by contamination, foreign matter adhesion, etc. (excluding cases for which we are responsible).
 - (3) If a consumable other than those designated by us was used in the product.
 - (4) If the product was used under special environments (such as high temperature/humidity, large amount of dust, corrosive/volatile/flammable gas atmosphere, decompressed/pressurized atmosphere and in a liquid, excluding, however, explicitly permitted range by us in the specification sheet, etc.).
 - (5) If the product was disassembled, reassembled, repaired or modified by anyone other than us.
 - (6) If failure is caused by a device other than the product.
 - (7) If failure is caused by fire, earthquake, lightning strike, flood disaster, or other force majeure.
 - (8) If failure is not caused by a defect in the design or manufacture of the product.
- 4 If the product is repaired or a replacement is delivered as described in Paragraph 1, the warranty period for the repaired/replaced parts or the replaced product shall be the remaining warranty period of the failed product.

Terms and Definitions

Rated pressure

The maximum operating pressure specified for each valve. Our warranty covers usage under this pressure (relief valve set pressure) or lower. This specification value can be found on the specification drawing and assembly drawing.

Rated flow rate

The maximum flow rate specified for each valve. Our warranty covers usage under this flow rate or lower. This specification value can be found on the specification drawing and assembly drawing.

Port

The piping connection port on the valve. This specification value can be found on the specification drawing and assembly drawing.

Pump port (P-port)

The port that connects a pump to the valve. Used to supply hydraulic fluid from the pump to the valve.

Tank port (T-port)

The port that connects a tank to the valve. Used to return hydraulic fluid discharged from the valve to the tank.

Actuator port (A-port and B-port)

The port that connects an actuator to the valve. Used to supply or discharge hydraulic fluid to/from the actuator.

Carry-over port (V-port)

The port that connects another valve to the valve. Used when using hydraulic fluid discharged from the valve in another valve or the like.

Hose connector

The piping component that is attached to the port when a pipe is connected to the valve port.

Actuator

A hydraulic cylinder, motor or the like that is connected to the valve.

Hydraulic system

A set of components that make up a hydraulic circuit, including pumps, valves, actuators, hydraulic fluid tanks, and pipes.

Center bypass system

When the spool is in the neutral position, the pump port connects to the tank port or carry-over port via the center bypass. The center bypass refers to a passage.

When you move the spool, it closes the center bypass and opens the actuator ports to supply hydraulic fluid to the actuators.

Parallel connection

The connection method that allows the pump port to connect to all the actuator ports. When you simultaneously change the positions of two or more spools, hydraulic fluid is supplied to the actuator ports operated simultaneously.

O-ring

Ring-shaped packing with circular cross section and used for sealing hydraulic oil.

Spring center

This refers to the condition that the spool is placed in its initial position at the center by the spring when the control lever is not manipulated.

Table of Contents

Introduction	2
Structure of the Operation Manual	3
Important Notes	4
1 Intended Use of the Product (Purpose of Use)	4
2 Precautions for Safe Use of the Product	4
3 Provision of Danger Information to Users	5
4 Disposal of the Product	5
5 Others	5
About This Manual	6
1 Target Audience	6
2 Contents of This Manual	6
3 Loss or Damage of/to This Manual	6
4 Publishing on the Website	6
5 Copyright	6
6 Trademark	6
Warranty	7
Terms and Definitions	8
Chapter 1 Safety	12
1.1 Warnings	12
1.2 Types and Meanings of Warnings	12
1.3 General Matters to Be Followed	13
Chapter 2 Overview of the Product	14
2.1 Overview of the Product	14
2.2 Type Indication	15
2.3 Names and Functions of Parts	16
Chapter 3 Specifications	18
3.1 Use Environment	18
3.2 Rating of the Product	18
3.3 Specifications of the Product	20
3.4 Names of Ports	21
3.5 Specifications of a Set of Control Lever Parts	22
3.6 Recommended Grease	23
Chapter 4 Unpacking	24
4.1 Precautions for Unpacking	24
4.2 Check of Packing Contents	24
4.3 Nameplate	26
Chapter 5 Carrying and Storage	27
5.1 Precautions to Take When Carrying the Product	27
5.1.1 When carrying the product by hand	27
5.1.2 When transporting with a sling (wire, sling belt, etc.)	27
5.2 Precautions for Product Storage Before Use	28
Chapter 6 Installation Preparation	29
6.1 Preparation of Necessary Components	29
6.1.1 Fixing Bolts	29
6.1.2 Piping Components	30

Chapter 7	Installation	32
7.1	Precautions During Installation	32
7.2	Installation into Machine	33
7.3	Installation of Piping Components	34
7.4	Mounting the Set of Control Lever Parts	35
Chapter 8	Operation	37
8.1	Items to Be Checked Before Operation	37
8.2	Precautions During Operation	38
Chapter 9	Maintenance and Inspection	39
9.1	Notes on Maintenance Work	39
9.2	Daily Inspection	40
9.3	Precautions for Storage after Use or after Installation of Set(s) of Control Lever Parts	41
Chapter 10	Removal and Disposal	42
10.1	Removal from Machine	42
10.2	Disposal Procedure	43
Chapter 11	Troubleshooting	44
Contact Information		45

Chapter 1 **Safety**

The safety information described in this chapter is intended to serve as guidelines for preventing injury to persons who carry, install, operate, maintain, inspect, remove and dispose of the product as well as damage to the product.

1.1 Warnings



This manual alerts the workers to dangers and to cautions regarding the product in the following way.

- “Chapter 1 Safety” describes the safety rules.
- Warnings are included in this manual.

1.2 Types and Meanings of Warnings

In this manual, one of the following warnings that fall into the four categories is given for a hazardous situation that may occur during operation.

Disregarding the warning may result in a life-threatening serious personal injury accident or substantial damage and malfunction to/of the product.

 DANGER	Death or serious personal injury is likely to occur if protective measures are not taken.
 WARNING	Death or serious personal injury may occur if protective measures are not taken.
 CAUTION	Minor personal injury may occur if protective measures are not taken.
NOTICE	Only property damage may occur if protective measures are not taken.

IMPORTANT	Important and useful information on product operation, maintenance and inspection
------------------	---

1.3 General Matters to Be Followed

Here are general precautions for safety use of the product.

Regarding the precautions for transportation, installation, operation, maintenance, inspection, removal and disposal, please be sure to check the details in the relevant chapter.



-
- Modification and disassembly of the product are prohibited.
The product may be break, resulting in a personal injury accident due to malfunction of the machine or damage to the machine.
 - Strong impact to the product and vibration are prohibited.
The product may be break, resulting in a personal injury accident due to malfunction of the machine or damage to the machine.
 - You must confirm that the use conditions of the machine matches the specifications of the product.
The specifications described in the specification drawing and assembly drawing are based on our company's evaluation method. Neglecting confirmation may result in a personal injury accident due to malfunction of the machine or damage to the machine.
 - Permit only those who understand this manual to carry out transportation, installation, operation, maintenance, inspection, removal and disposal of the product. The operator or the person responsible for work management must forbid anybody who has not understood the contents of this manual to perform the operation. The product may be broken, resulting in a personal injury accident due to malfunction of the machine or damage to the machine.
 - Use only the consumables and replacement parts made or specified by us. Using anything other than the above may damage the product, resulting in a personal injury accident due to malfunction of the machine or damage to the machine.
-



-
- Workers should use tools suitable for their work.
Using damaged or deteriorated tools, or using tools for purposes other than their intended use, may result in injury to the worker.
 - Workers should wear appropriate clothing and protective equipment.
When handling the product, there is a risk of injury.
 - When the weight is unknown, use a crane or other lifting device.
Workers may hurt their back or suffer other health problems, trying to lift the heavy product.
-

Chapter 2 Overview of the Product

This chapter describes the part names and functions, and how to use the product.

2.1 Overview of the Product

The product is designed and manufactured as a device that distributes hydraulic fluid coming from the hydraulic pump to the actuators connected to the product to operate each actuator.

It is a control valve that moves the spool by manually operating the control lever.

Two fluid discharge types, T-port and V-port types, are available, and you can select the actuator port module count from 1 to 8 for each port type. The module count means the quantity of actuator port modules.

The circuit configuration is as shown below.

- Center bypass system
When the control lever is not operated, the spool is returned to neutral because of spring center, and the pump and tank ports or the pump and carry-over ports are connected. The hydraulic fluid supplied from the pump port passes through the center bypass, being discharged from the tank port or the V-port. When the control lever is operated, the center bypass between the pump and tank ports or between the pump and carry-over ports is closed by the spool. The actuator port is opened and hydraulic fluid from the pump port is supplied to the actuator connected to the actuator port.
- Parallel connection
If the control levers of two or more actuator port modules are operated simultaneously in a product with the multiple modules, hydraulic fluid is supplied to the actuator ports of the modules operated simultaneously. Operation starts with the actuator corresponding to the actuator port module that requires the least load pressure.
- T-port type
This valve discharges hydraulic fluid supplied from the pump port via the tank port.
- V-port type
This valve can send hydraulic fluid supplied from the pump port to another valve via the carry-over port.

2.2 Type Indication

This section describes the type indication described in the specification drawing and assembly drawing. Please see Fig. 2-1.

The nameplate on the product includes the part number and the serial number (S/N).

Please see Table 2-1. Regarding the mounting position of the nameplates, please refer to “4.3. Nameplate.”

When making an inquiry, please provide us with the part number and serial number (S/N).

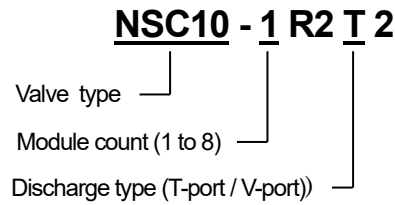

Fig. 2-1 Type Indication

Table 2-1 Type and Part Number

Discharge Type	Module Count	Type (included in specification drawing and assembly drawing)	Part Number
T-port type	1	NSC10-1R2T2	220338-01
	2	NSC10-2R2T2	220339-01
	3	NSC10-3R2T2	220340-01
	4	NSC10-4R2T2	220341-01
	5	NSC10-5R2T2	220342-01
	6	NSC10-6R2T2	220343-01
	7	NSC10-7R2T2	220344-01
	8	NSC10-8R2T2	220345-01
V-port type	1	NSC10-1R2V2	220346-01
	2	NSC10-2R2V2	220347-01
	3	NSC10-3R2V2	220348-01
	4	NSC10-4R2V2	220349-01
	5	NSC10-5R2V2	220350-01
	6	NSC10-6R2V2	220351-01
	7	NSC10-7R2V2	220352-01
	8	NSC10-8R2V2	220353-01

2.3 Names and Functions of Parts

This section describes the names of the parts.

IMPORTANT

- The shape of your product may be different from the figure below, depending on the number of actuator port modules you ordered.
- If the shape is different from the figure below, see the external dimensions in the specification drawing and assembly drawing.
- The module count means the quantity of actuator port modules.

(1) T-port type

Fig. 2-2 shows NSC10-1R2T2 (with one module).

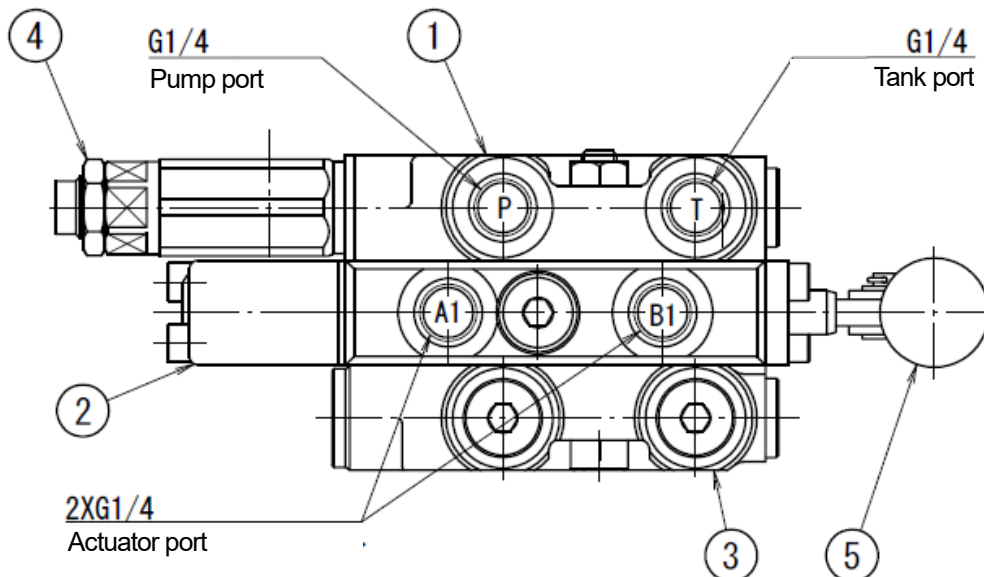

Fig. 2-2 Example of T-port Type

Table 2-2 Names and Descriptions

No.	Name	Description
1	Supply part	Has a pump port (P) for T-port type.
2	Actuator port module	One to eight actuator port modules can be connected.
3	Discharge part	Has a tank port (T) for T-port type.
4	Relief valve	Limits the max. pressure in the hydraulic circuit to a set value.
5	Set of control lever parts	Is packaged together as the attachments for the product's main body, an assembly of above Nos. 1 to 4 in this table. One set of control lever parts is attached to each actuator port module.

(2) V-port type

Fig. 2-3 shows NSC10-2R2V2 (with two modules).

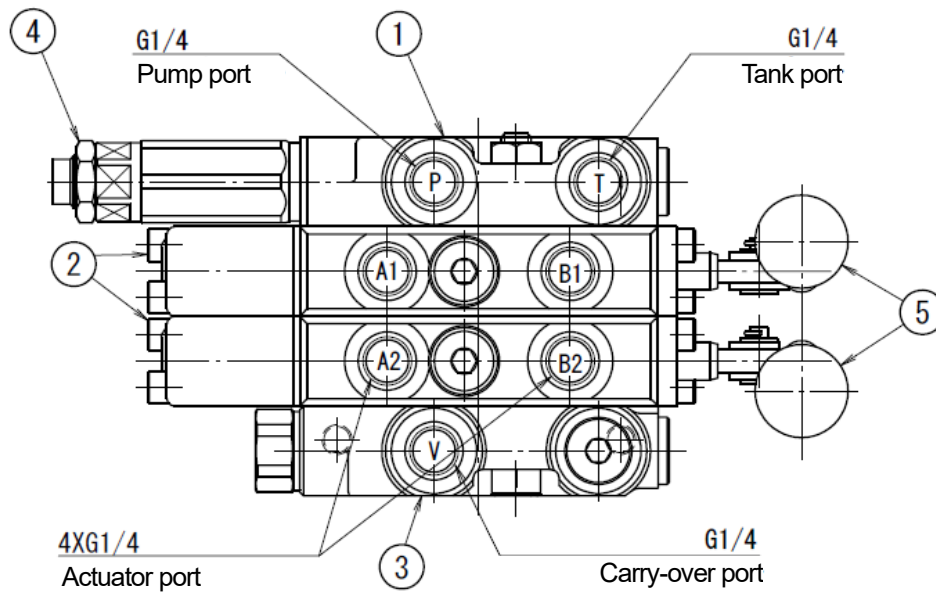

Fig. 2-3 Example of V-port Type

Table 2-3 Names and Descriptions

No.	Name	Description
1	Supply part	Has a pump port (P) and a tank port (T) for V-port type.
2	Actuator port module	One to eight actuator port modules can be connected.
3	Discharge part	Has a carry-over port (V) for V-port type.
4	Relief valve	Limits the max. pressure in the hydraulic circuit to a set value.
5	Set of control lever parts	Is packaged together as the attachments for the product's main body, an assembly of above Nos. 1 to 4 in this table. One set of control lever parts is attached to each actuator port module.

Chapter 3 Specifications

This chapter describes the specifications of the product.

3.1 Use Environment

You must use the product in an environment that meets the following conditions.

- Ambient temperature is between -20 to +50°C
- Humidity is 85% or less (non-condensing)
- Not directly affected by wind and rain

You must NOT install the product in any of the following places.

- Dusty place
- Outdoors directly affected by wind and rain
- Flammable/explosive/corrosive gas atmosphere and areas near combustibles
- Location where a magnetic field or vibration is generated

IMPORTANT

- If the above requirements for use environment cannot be met, please consult our customer service in advance.
- If you intend to use the product in a special environment (clean room, food facility, medical facility, concentrated alkali, exposure to high pressure steam, etc.), please consult our customer service in advance.

3.2 Rating of the Product

The rated pressure and flow rate of the product are as shown below.

Rated pressure: 20.6 MPa

Rated flow rate: 15 L/min

Relief valve set pressure: 20.6 MPa

Other detailed specifications are found on the specification drawing and assembly drawing.

WARNING

- Keep the pressure below the rated pressure.
The product may be broken, resulting in a personal injury accident due to malfunction of the machine or damage to the machine.
- Use below the rated flow rate.
The product may be broken, resulting in a personal injury accident due to malfunction of the machine or damage to the machine.
- Use hydraulic fluids with cleanliness grade 9 or below in NAS.
If you use hydraulic fluid with poor cleanliness, debris may get caught in the internal seal, causing its failure or the seal may be damaged. A personal injury accident may be caused by malfunction of the machine or damage to it may occur.



-
- Use general mineral hydraulic fluid.
 - Piping must enable the tank back pressure to be 0.98 MPa or less.
-

3.3 Specifications of the Product

Table 3-1 shows the weight and external dimensions of the product. Fig. 3-1 shows NSC10-2R2V2 (with two modules).

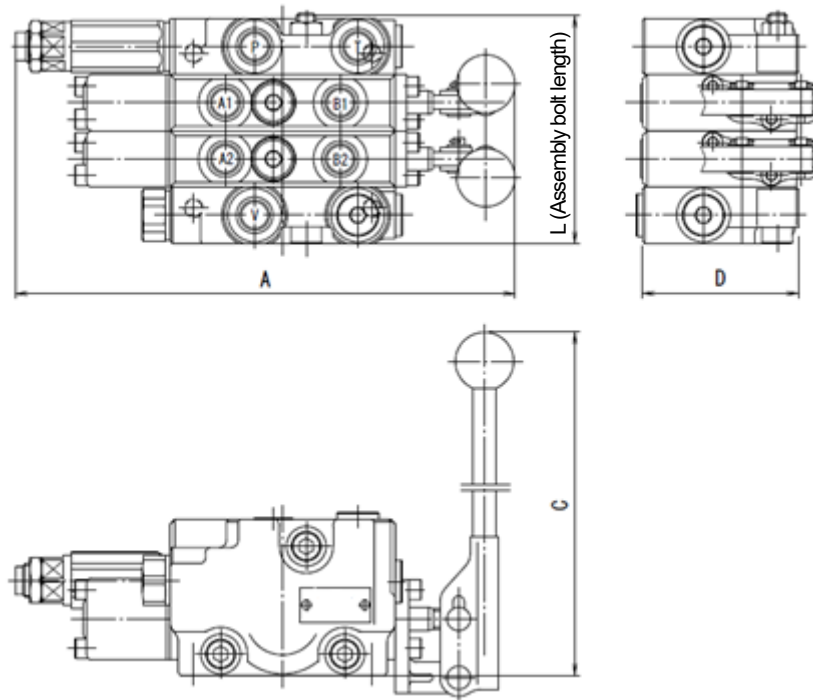

Fig. 3-1 Outline Drawings

Table 3-1 Specifications of the Product (Main Body Weight and External Dimensions by Type)

Discharge type	Module count	Type	Weight *1 (kg)	Dimensions (mm)			
				A	L	C	D
T-port type	1	NSC10-1R2T2	2.8	213	73	209	67
	2	NSC10-2R2T2	3.9		98		
	3	NSC10-3R2T2	5.0		120		
	4	NSC10-4R2T2	6.2		144		
	5	NSC10-5R2T2	7.3		168		
	6	NSC10-6R2T2	8.4		196		
	7	NSC10-7R2T2	9.5		220		
	8	NSC10-8R2T2	10.7		244		
V-port type	1	NSC10-1R2V2	2.8	213	73	209	67
	2	NSC10-2R2V2	3.9		98		
	3	NSC10-3R2V2	5.0		120		
	4	NSC10-4R2V2	6.2		144		
	5	NSC10-5R2V2	7.3		168		
	6	NSC10-6R2V2	8.4		196		
	7	NSC10-7R2V2	9.5		220		
	8	NSC10-8R2V2	10.7		244		

*The weight in Table 3-1 shows the product main body weight, excluding the attachments. The weight of packing material is also not included.

3.4 Names of Ports

The following describes the port names.

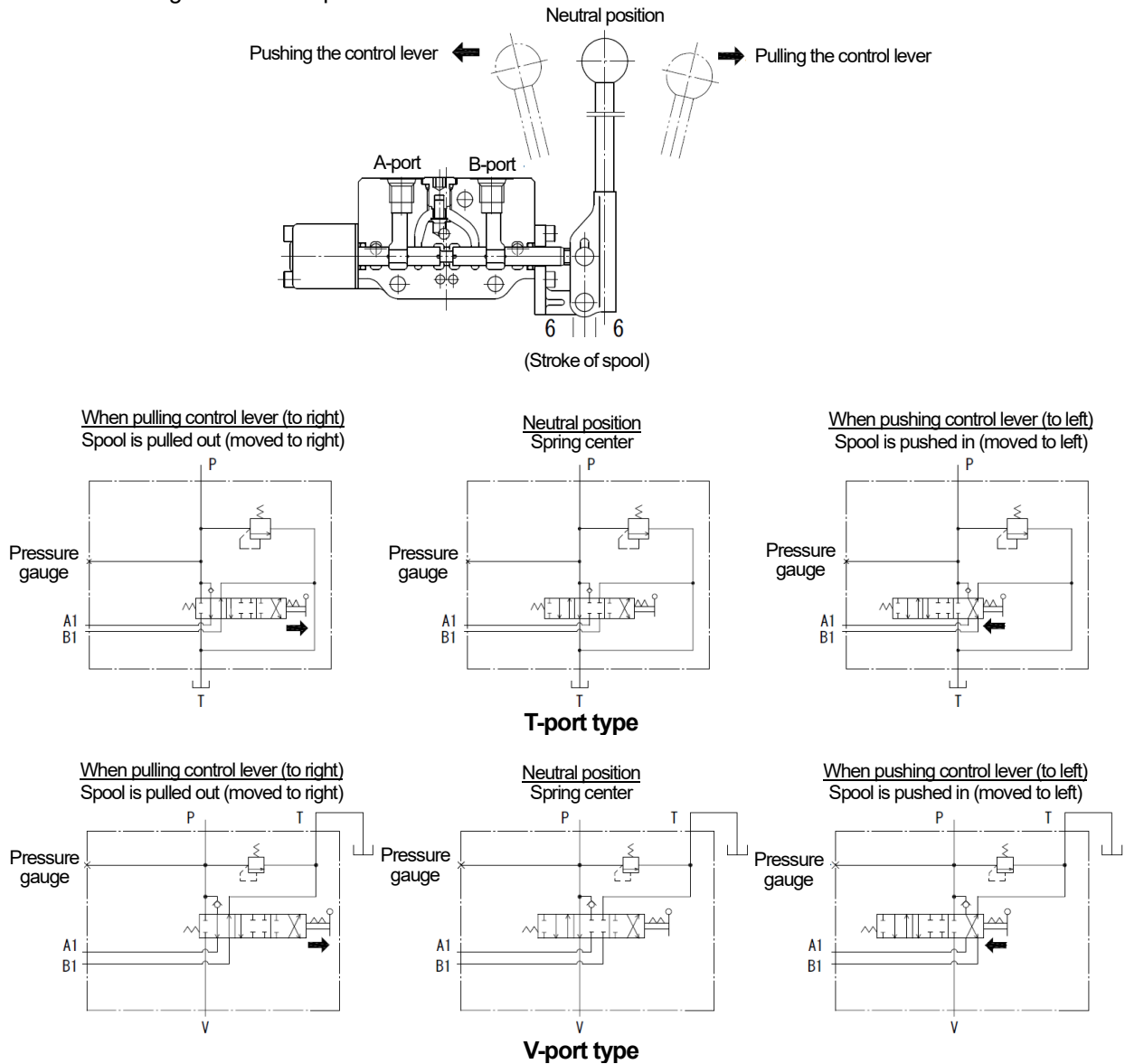

Fig. 3-2 About Ports

Table 3-2 Specifications of Ports

Symbol	Name and Port Sizes	Descriptions
P	Pump port G1/4	Connects to a pump.
A	Actuator port G1/4	Connects to an actuator. Push the control lever to connect the port to the pump port. Control lever pulling (Right) -> Spool pulling out (Right)
B	Actuator port G1/4	Connects to an actuator. Pull the control lever to connect the port to the pump port. Control lever pushing (Left) -> Spool pushing in (Left)
T	Tank port G1/4	Connects to a tank. The position is different between T- and V-port types.
V	Carry-over port G1/4	Is provided for V-port type only.
-	Pressure gauge port Rc1/8	Can install a pressure gauge to measure hydraulic fluid pressure.

- * According to the module count of the product, the sets of control lever parts with “●” added to their part numbers in Table 3-3 are packed as attachments to the main body of the product.
- * The numbers in the No. column in Table 3-3 correspond to the numbers assigned to the control lever parts in Fig. 3-3.

3.6 Recommended Grease

This section describes the lubricant used in the product.

NOTICE

- When storing the product for a long period of time, you should properly apply the grease recommended in Table 3-4 to the moving parts of the control lever.

Table 3-4 Recommended Grease

Manufacturer	Product Name
Idemitsu Kosan Co., Ltd.	Daphne Eponex. SR No.0

Chapter 4 Unpacking

This chapter describes the precautions and necessary materials for unpacking.

4.1 Precautions for Unpacking



- When unpacking, be extremely careful not to tip over or drop the product. Such overturning or falling may cause a personal injury accident and damage to the product.
- During unpacking, check the packing contents to make sure that you have all the items you ordered. If a wrong product is installed in the machine, the product may be damaged, resulting in a personal injury accident due to malfunction of the machine or damage to the machine.

4.2 Check of Packing Contents

IMPORTANT

- For inquiries about the product, the part number and serial number (S/N) are necessary. You should keep a record of the part number and serial number (S/N) on the nameplate.
- Depending on the number of actuator port modules you ordered, the shape of the assembled control lever may differ from Fig. 4-3. If there is anything missing, please contact our customer service.

Procedure for Checking Packing Contents

- Step 1** Confirm that the number of the ordered product selected in the specification drawing and assembly drawing matches the item code (part number) on the shipping label on the outside of the packing box.



Fig. 4-1 Example of Shipping Label

- Step 2** Make sure that the main body of the product and the set(s) of control lever parts are packed in the box. When unpacking, you will see the set of control lever parts that have been assembled as shown in Fig. 4-3. Confirm that the packing contents match those shown in Table 4-1 and their quantities are correct.



- The lever and the knob cannot be separated. You must not force them apart. The knob may come off during operation and the operator may be injured.

The part number 2371-3-171167-XX (set of control lever parts) includes the following parts.

Table 4-1 Set of Control Lever Parts

No.	Name	Set of control lever parts Quantity per set
1	Lever	1
2	Pin	2
3	Washer (small) M5	2
4	Snap pin SSP-5	2
5	Knob	1

* For the specifications of a set of control lever parts, please see Table 3-3.

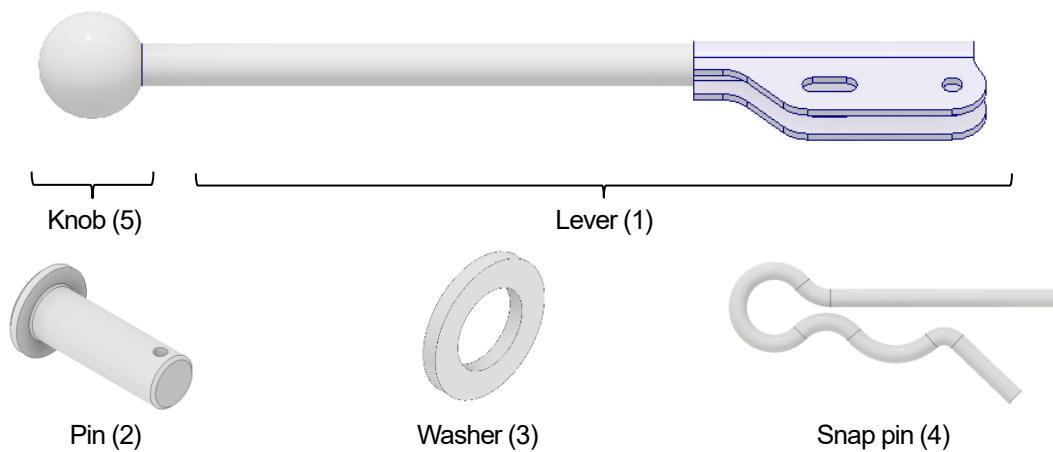

Fig. 4-2 Packing Contents

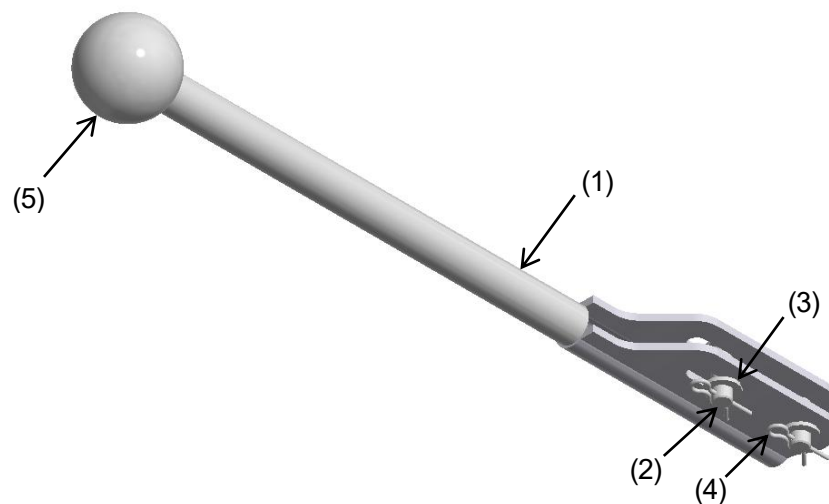

Fig. 4-3 Set of Control Lever Parts (Part Number: 2371-3-171167-XX)

4.3 Nameplate

The mounting position of the nameplate is as shown in Fig. 4-4.

IMPORTANT

- Peeling or staining the nameplate is forbidden.
For inquiries, you will need the part number and serial number (S/N) described on the nameplate.

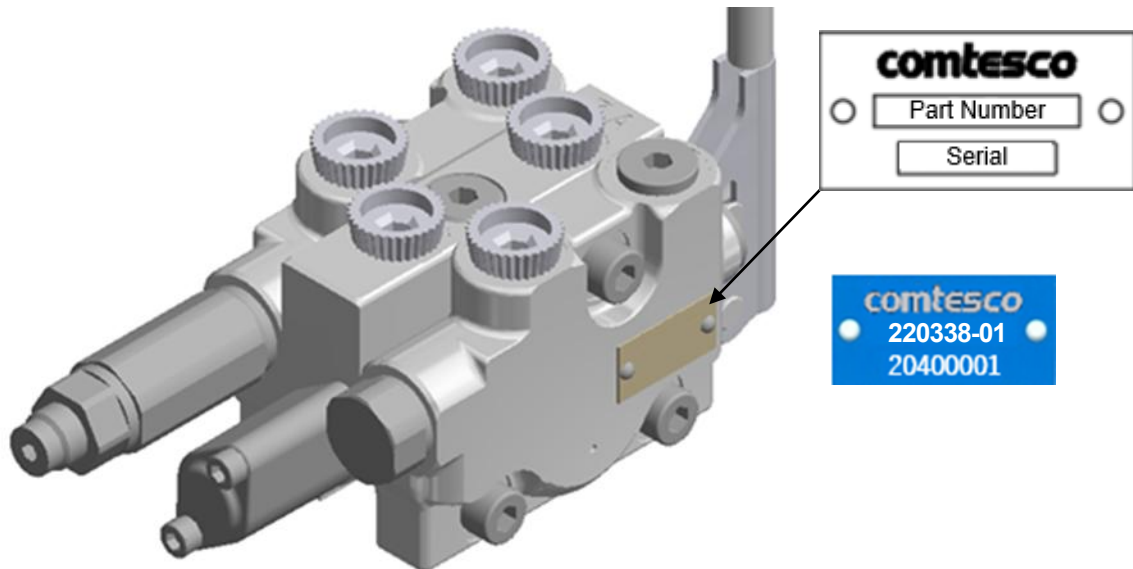

Fig. 4-4 Nameplate

Chapter 5 Carrying and Storage

This chapter describes the precautions to follow when carrying and storing the product.

5.1 Precautions to Take When Carrying the Product



-
- Strong impact to the product and vibration are prohibited.
The product may be broken, resulting in a personal injury accident due to malfunction of the machine or damage to the machine.
 - The product removed from the packaging box has to be carried with the masking plugs attached until it is installed in the machine.
Dust may intrude into the hydraulic circuit of the product, causing a personal injury accident due to malfunction of the machine.
 - Do not carry the product with its packing box stacked.
The packing box may be crushed, and its collapsing or falling may cause a personal injury accident or damage to the product.
 - Do not stack the packing box with the product in them. Or do not place anything on a packing box that contains the product. The packing box may be crushed, and its collapsing or falling may cause a personal injury accident or damage to the product.
-



-
- When carrying the product, you must take the weight of the product into consideration.
The weight changes depending on the number of actuator port modules.
 - If you carry the too heavy product by hand, you may hurt your back or suffer other health problems.
Check the relevant national and local laws and regulations.
 - When carrying the product by hand, support its bottom.
 - Use a crane depending on the weight of the product. When it is used, a qualified person has to operate it.
 - When carrying the product, do not hold the low-strength parts such as spool lid and spool by hand nor attach slings to them.
-

5.1.1 When carrying the product by hand

Step 1 Check that the product has masking plugs.

Step 2 Check the weight of the product in Table 3-1 in “3.3 Specifications of the Product.”

Step 3 Wear protective equipment such as anti-slip work gloves and safety shoes.

Step 4 Firmly support the underside of the product and lift it slowly.

5.1.2 When transporting with a sling (wire, sling belt, etc.)

Step 1 Check that the product has masking plugs.

Step 2 Check the weight of the product in Table 3-1 in “3.3 Specifications of the Product.”

- Step 3** Wear protective equipment such as anti-slip work gloves and safety shoes.
- Step 4** Check the maximum working load of the sling to be used in its catalog or the like, and make sure that the weight of the product does not exceed the limit.
- Step 5** Attach the slings to the product's main body as shown in Fig. 5-1, and confirm that it is securely fixed.
- Step 6** Slowly lift the main body using a crane.
Make sure that it is kept level, and move it while reducing shaking.

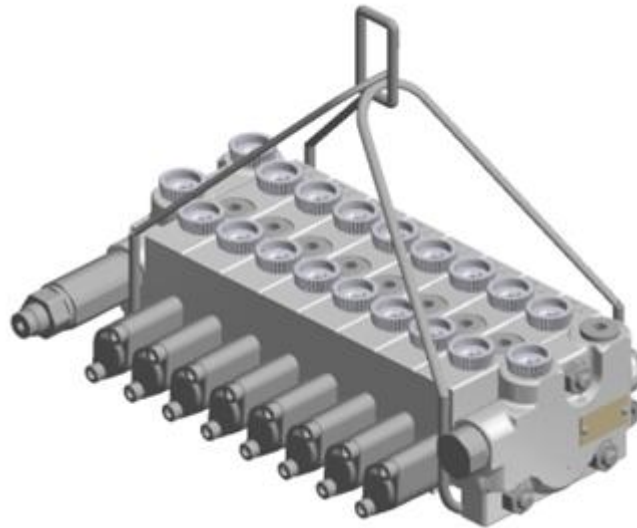

Fig. 5-1 Example of Using Sling

5.2 Precautions for Product Storage Before Use

NOTICE

- If the product needs long-term storage, periodically check its condition and apply rust prevention treatment as necessary. There is a risk of rust or corrosion.
- Do not store the product in a corrosive atmosphere or in a high temperature and humidity environment exceeding the specifications.
Its corrosion or deformation/cracking of its seals may be caused.

IMPORTANT

- For information on how to store the product after use or after installing a set of control lever parts, see "9.3 Precautions for Storage after Use or after Installation of Set(s) of Control Lever Parts."

Pre-use storage procedure

- Step 1** Make sure that a masking plug is attached to each port of the product.
- Step 2** Apply rust preventive, cover the product with a plastic bag or the like, and put it in the packing box.

Chapter 6 Installation Preparation

This chapter describes the components that you need to prepare.

6.1 Preparation of Necessary Components

This section describes the mounting hardware (fixing bolts and piping components) to be prepared by the customer.

IMPORTANT

- The shape of your product may be different from the figure below, depending on the number of actuator port modules you ordered.
If the shape is different from the figure below, see the external dimensions in the specification drawing and assembly drawing.
Prepare a drawing that shows the mounting dimensions for the product.

6.1.1 Fixing Bolts

This section describes the fixing bolts used to install the product in the machine.

WARNING

- Select M8 as the size of the fixing bolts and check the following items to decide on the length. If the bolt is too long, the product may be damaged, causing a personal injury accident due to malfunction of the machine or damage to the machine.
 - Depth of the mounting screw hole in the product (For the specific values, see the specification drawing and assembly drawing. In the example shown in Fig. 6-1, the depth of the mounting screw hole is 12 mm.)
 - Thickness of the mounting plate in the machine
- The flatness of the mounting surface for the product must be 0.3 mm or less.
If the flatness is not ensured, the product may be subjected to excessive loads and damaged, resulting in a personal injury accident due to malfunction of the machine or damage to the machine.

Procedure for preparing fixing bolts

- Step 1** Prepare the specification drawing and assembly drawing and the operation manual of the machine.
- Step 2** Select the fixing bolt after checking the depth of the mounting screw hole in the product and the thickness of the mounting plate in the machine. (In the example shown in Fig. 6-1, the depth of the mounting screw hole is 12 mm.)

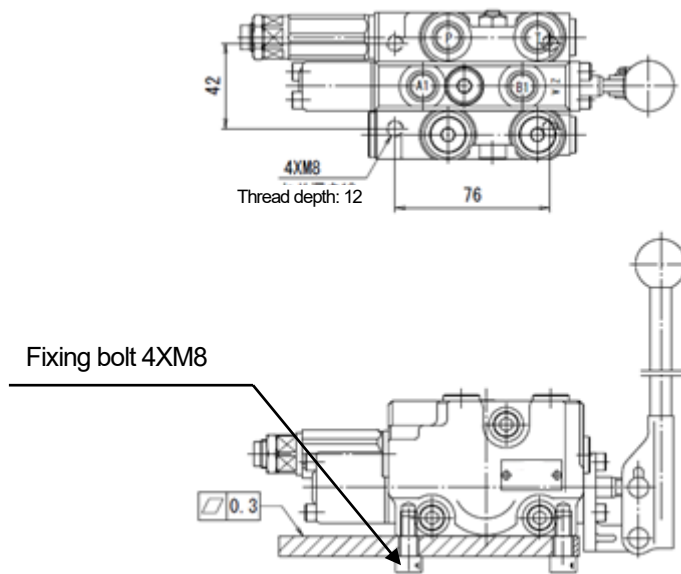

Fig. 6-1 Fixing Bolts

6.1.2 Piping Components

This section describes the piping components that connect the individual ports of the product's main body to the individual actuators of the machine.



- Select the piping components (hose connector and hose) that have their rated pressure equal to or higher than the product's relief valve set pressure. For the information on the relief valve set pressure, see the specification drawing and assembly drawing. If their rated pressure is lower than the relief valve set pressure, the product may be damaged, resulting in a personal injury accident due to malfunction of the machine or damage to the machine.
- Each port of the product uses parallel pipe threads (G). See Fig. 6-2. If you use a hose connector with threads of a different standard, the product may be damaged, resulting in a personal injury accident due to malfunction of the machine or damage to the machine.

Procedure for preparing piping components

- Step 1** Prepare the specification drawing and assembly drawing.
- Step 2** Check the type and quantity of the individual ports in the product.
- Step 3** Select a hose connector that is intended for the ports with parallel pipe threads (G) and that has the rated pressure equal to or higher than the product's relief valve set pressure.
- Step 4** Prepare one hose connector for each port of the product.
- Step 5** Check that the hose connector has an O-ring.

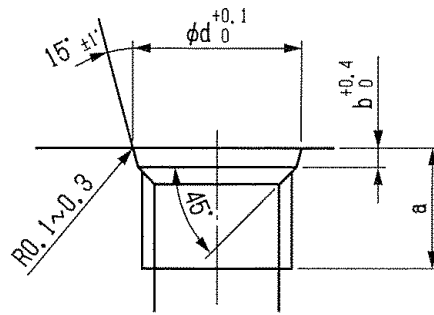

Fig. 6-2 Shape of Port with Parallel Pipe Threads (G)

Table 6-1 Port Sizes of Parallel Pipe Threads (G)

Port size	Dimensions (mm)		
	Φd	a	b
G 3/8	18.6	13	2.5
G 1/2	22.6	18	

Chapter 7 Installation

This chapter describes the precautions for installation of the product, installation in the machine, and installation procedures for pipes and the set of control lever parts.

7.1 Precautions During Installation

WARNING

- Do not drop or bump the product.
The product may be broken, resulting in a personal injury accident due to malfunction of the machine or damage to the machine.
- Attach the main body of the product to the machine and install the piping before mounting the set of control lever parts on the main body. If you attach the set of control lever parts first and then try to install the product in the machine, they may interfere with product installation into the machine or piping installation, causing activation failure of the product and a personal injury accident due to malfunction of the machine.
- Leave the masking plug attached to each port of the product as it is until a pipe is installed. Dust may intrude into the hydraulic circuit of the product, causing a personal injury accident due to malfunction of the machine.
- Use a crane depending on the weight of the product. When it is used, a qualified person has to operate it.

CAUTION

- Workers should use tools suitable for their work.
Using damaged or deteriorated tools, or using tools for purposes other than their intended use, may result in injury to the worker.
- Workers should wear appropriate clothing and protective equipment.
When handling the product, there is a risk of injury.
- To be prepared for leakage of hydraulic oil, place an oil pan or the like.
Hydraulic fluid remaining inside the product may leak out when removing the masking plugs, and the worker may be injured unexpectedly due to a slip-and-fall accident.
- Do not work in an awkward position in an unstable place.
There is a risk that the worker may hurt his/her back or a part of body.

NOTICE

- If a screw is hard to turn or the product interferes with the machine, do not try to install it. There is a risk of damage or deformation of the product.

IMPORTANT

- The installation environment of the product must meet the requirements shown in “3.1 Use Environment.”

7.2 Installation into Machine

This section describes the procedure to install the main body of the product to the machine.



- Leave the masking plug attached to each port of the product's main body as it is. Dust may intrude into the hydraulic circuit of the product, causing a personal injury accident due to malfunction of the machine.
- When installing the product, use the specified bolts and tighten them with the specified torque. If it is tightened with a torque outside the specified range, the product may be broken, resulting in a personal injury accident due to malfunction of the machine or damage to the machine.

- Step 1** Prepare the specification drawing and assembly drawing.
- Step 2** Check whether the prepared fixing bolts have the same specifications as the selected ones.
- Step 3** Check that the flatness of the mounting surface for the product's main body is 0.3 mm or less in the machine.
- Step 4** Pass the fixing bolts through the mounting holes in the product's main body, and screw them into the mounting surface of the machine.
- Step 5** Tighten the fixing bolts to the mounting surface of the machine with the recommended torque of 19.6 ± 0.98 N·m.

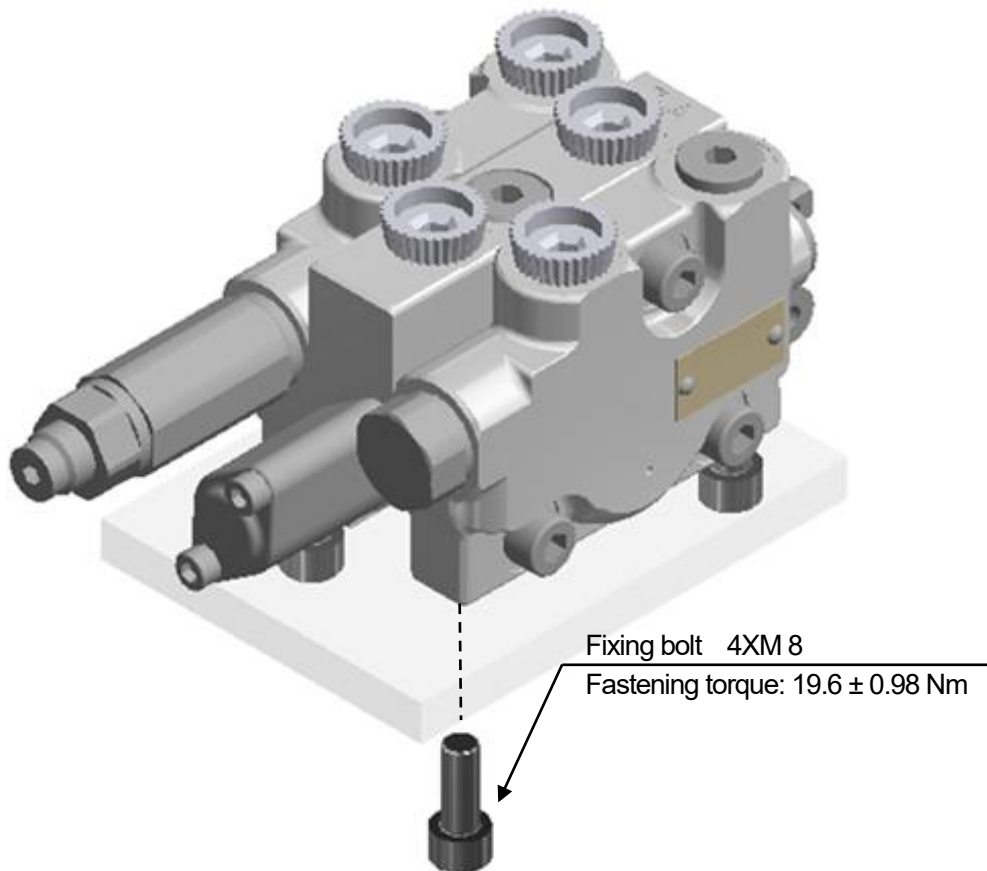

Fig. 7-1 Installation into Machine

7.3 Installation of Piping Components

The following describes the procedure for installing the piping into the main body of the product.



- Remove the masking plugs only from the port where a pipe is will be installed, among the individual ports of the product's main body. Dust may intrude into the product, causing a personal injury accident due to malfunction of the machine.
- Install the piping correctly.
The product may be broken, resulting in a personal injury accident due to malfunction of the machine or damage to the machine.
- All the ports of the product require pipe connection. The masking plugs cannot withstand strong pressures. While a masking plug(s) is attached, if you operate the control lever, this may cause a personal injury accident due to spouting or scattering of hydraulic fluid.

Step 1 To be prepared for leakage of hydraulic fluid, place an oil pan, waste cloth and so on.

Step 2 Confirm the locations and types of the pump port, tank port and actuator ports of the product with the specification drawing and assembly drawing.

Step 3 Remove the masking plugs only from the port where a pipe is will be installed.

IMPORTANT

- If dust remains inside a pipe, clean it with a cleaning solution and air blow.
- Use a cleaning solution if there are oil stains.
- Keep the removed masking plugs since they may be used during piping installation or when the product is being removed from the machine.

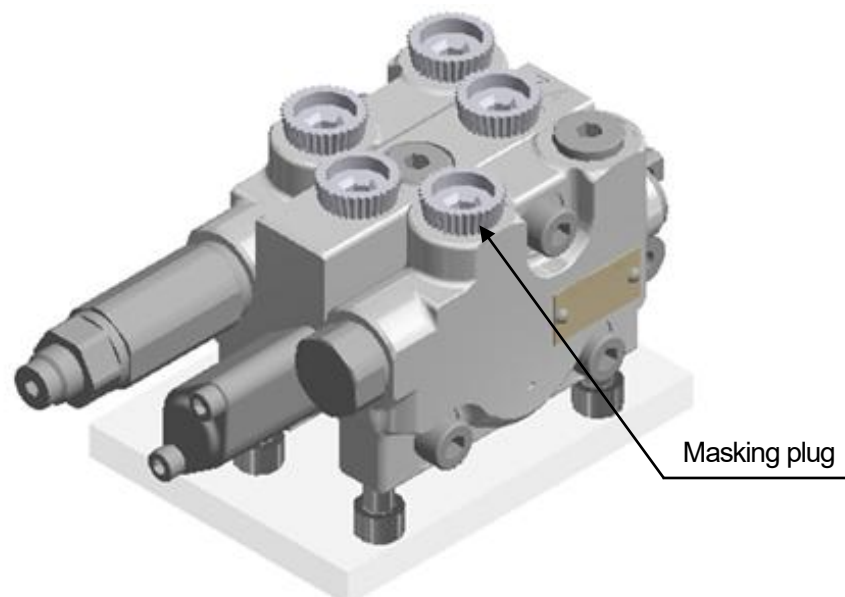

Fig. 7-2 Removal of Masking Plug

Step 4 Screw the hose connector into the port from which the masking plug was removed.



- Tighten the hose connector to the recommended torque shown in Table 7-1.
If it is tightened with a torque outside the specified range, the product may be damaged, resulting in a personal injury accident due to malfunction of the machine or damage to the machine.
- Regarding installation procedure and tightening torque of hose fittings at the end of hose, check the manufacturer's catalog.
Tightening with torque outside the specified range may deform or damage the hose connectors and hose fittings, causing a personal injury accident due to malfunction of the machine or damage to the machine.

Step 5 Tighten the hose connector to the recommended torque. Check Table 7-1 for the tightening torque.

Table 7-1 Recommended tightening torque

Port size	Recommended torque (N·m)
G 1/4	24.5 ~ 29.4

Step 6 Screw the hose fittings at the end of the hose into the hose connector.

Step 7 Tighten the hose fittings according to the manufacturer's recommended procedure and torque. Check the manufacturer's catalog for the tightening torque.

7.4 Mounting the Set of Control Lever Parts

The following describes the procedure for mounting a set of control lever parts on the product.



- Mount the set of control lever parts on the main body of the product in the correct orientation.
If the set is attached upside down, the direction of operation for the lever and the direction of actuation for the machine will be reversed, causing a possible personal injury accident due to malfunction of the machine or damage to the machine.
- Check the type of the set of control lever parts in the specification drawing and assembly drawing and mount it on the correct position.
The bend degree of the control lever differs depending on the position where it is attached. For the type of the set of control lever parts, see "3.5 Specifications of a Set of Control Lever Parts." If a wrong control lever is forcibly attached, the product may be damaged, causing a personal injury accident due to malfunction of the machine or damage to the machine.
- Insert the snap pin securely. If the snap pin comes off while the machine is in operation, the pin falls off and lever operation becomes impossible. As a result, the machine may malfunction resulting in a personal injury accident or the machine may be damaged.

Step 1 Check the mounting position of each set of control lever parts on the specification drawing and assembly drawing.

- Step 2** At the time of unpacking, the set of control lever parts has been assembled as shown in Fig. 4-3. Remove the snap pin (4) from the pin (2) and disassemble the set of control lever parts.
- Step 3** Of the two holes in the lever (1), align the long hole closer to the knob with the hole in the spool (6). In addition, align the other round hole on the far side from the knob with the hole in the lid (5) on the lever side of the main body of the product.
- Step 4** Insert each pin (2) respectively into the two holes aligned between the lever (1) and the body of the product, fit each washer (3) onto each pin (2), and insert each snap pin (4) into each pin's (2) hole.

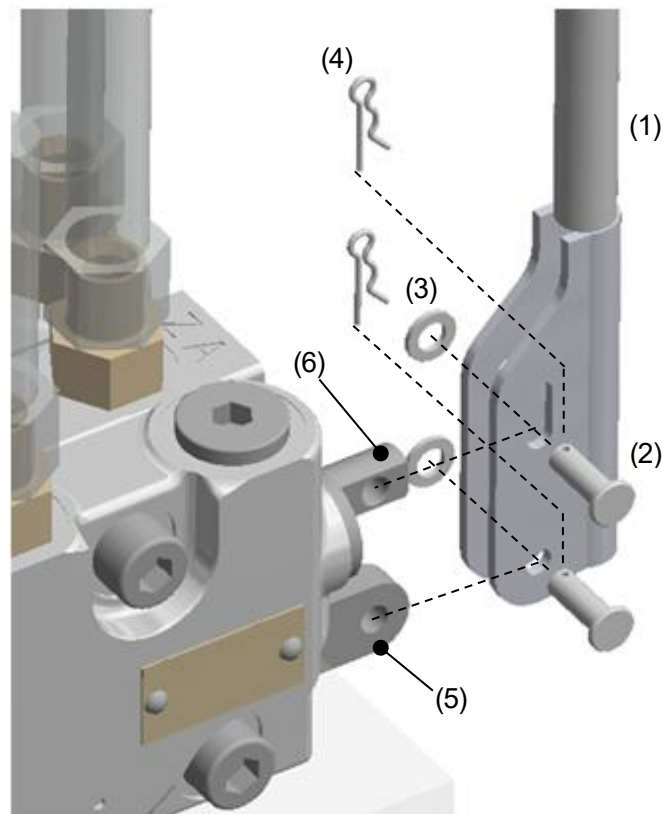

Fig. 7-3 How to Mount the Set of Control Lever Parts

Chapter 8 Operation

This chapter describes the precautions and checking procedures to follow when operating the product.

8.1 Items to Be Checked Before Operation

You must check safety according to the Industrial Safety and Health Law and the standards of the industry to which the machine belongs.

The items to be checked before starting operation are as follows:

- whether the product is properly installed and fixed in/to the machine.
- whether the piping is securely installed in the correct position.
- whether the actuators operate in the planned direction.

Checking procedure

Step 1 Operate the control lever of the product in small steps to confirm that the intended actuator is started in the correct direction. For information about the hydraulic fluid discharge port, see “3.4 Names of Ports.”

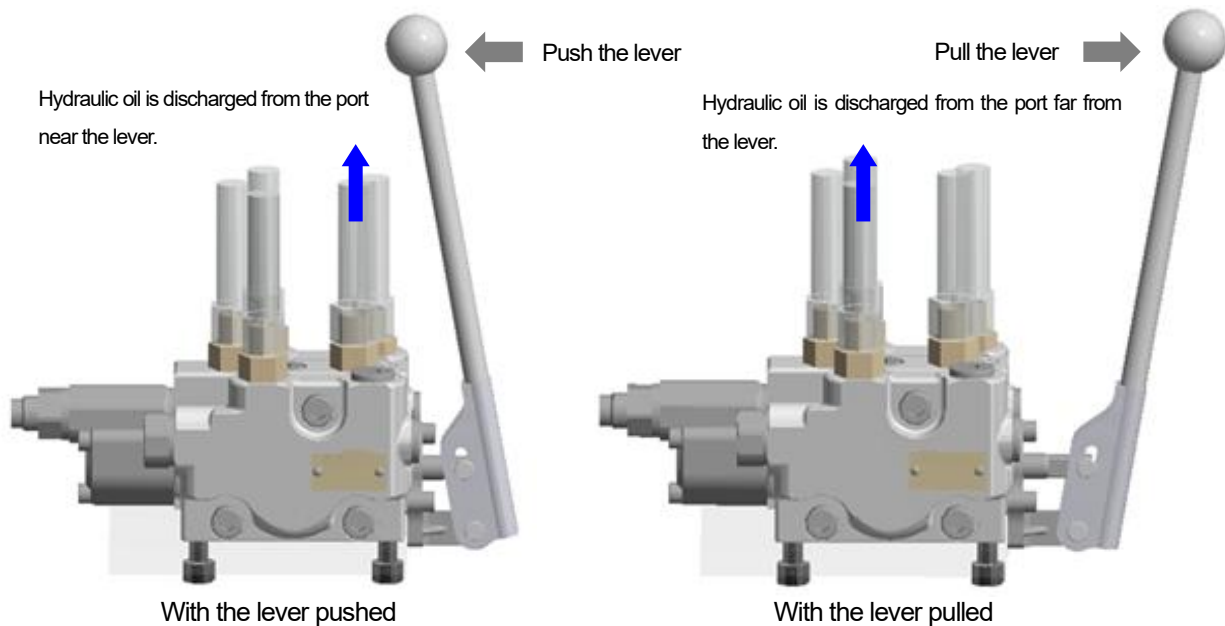

Fig. 8-1 Discharge Port of Hydraulic Fluid

Step 2 Repeat the lever push and pull to activate the actuator and remove air from the hydraulic system.

Step 3 Check the amount of hydraulic fluid in the tank with all the actuators extended (when the level in the hydraulic fluid tank is at its lowest). Refill the tank if the amount is not enough. When replenishing hydraulic fluid, check the operation manual of the machine.

Step 4 Operate the lever at the stroke end of the actuator to check for fluid leaks and temperature at each part of the machine.

8.2 Precautions During Operation

This section describes the precautions for operation.



-
- Use the product and piping components below their rated pressure and flow rate.
The product may be broken, resulting in a personal injury accident due to malfunction of the machine or damage to the machine.
 - Do not remove any pipes or parts of the product while the machine is in operation. There is a risk of a personal injury accident due to malfunction of the machine caused by scattering of parts or spouting of hydraulic fluid.
 - Do not enter the working area of the machine.
There is a risk of getting caught in moving parts, collision, or personal injury accident.
 - If any abnormal noise or condition occurs, stop operation immediately.
Do not operate the product until the cause of the problem has been determined and corrective measures have been taken.
The product may be broken, resulting in a personal injury accident due to malfunction of the machine or damage to the machine.
 - Do not put your finger or object in the moving parts (around the set of control lever parts) of the product.
Your finger may get caught in the moving parts, or malfunction of the machine may cause a personal injury accident.
-



-
- During operation of the machine, do not touch the main body of the product, piping, etc. except for the control lever. The product and the hydraulic system are hot during operation. Touching them may cause a burn injury.
 - Workers should wear appropriate clothing and protective equipment.
When handling the product, there is a risk of injury.
-

NOTICE

-
- Operate under the conditions that allow the temperature range of used hydraulic fluid to be -20 to +80°C. Otherwise, hydraulic fluid and the O-rings used inside the product may deteriorate prematurely.
-

Chapter 9 Maintenance and Inspection

This chapter describes the precautions for maintenance and inspection of the product and the daily inspection items.

9.1 Notes on Maintenance Work



-
- When removing the product or pipes, place the machine in the position where the actuators do not move. Unintended activation of the machine may result in a personal injury accident.
 - Do work on a dustproof and flat surface. If dust intrudes into the product or the hydraulic circuit, activation failure or malfunction of the machine may occur, resulting in a personal injury accident.
 - To ensure the complete stop of the machine, keep the power source for the pump in the OFF state. If you do work while the power source for the pump is ON, there is a risk of a personal injury accident due to malfunction of the machine.
-



-
- Workers should use tools suitable for their work.
Using damaged or deteriorated tools, or using tools for purposes other than their intended use, may result in injury to the worker.
 - Workers should wear appropriate clothing and protective equipment.
When handling the product, there is a risk of injury.
 - Do not touch the main body of the product or the hydraulic system until their temperatures drop after stopping the operation of the machine. Touching them may cause a burn injury.
-

9.2 Daily Inspection

This section describes the daily pre-operation check.



- Do not enter the operating area of the machine to inspect the product while the machine is in operation.
There is a risk of personal injury accident due to malfunction of the machine.
- When working together with the operator, signal each other to perform inspection.
Neglecting to give each other signals may cause a personal injury accident due to incorrect operation of the machine.

Before daily work, you must check the following items.

Table 9-1 Daily Inspection Items

Check Items	Inspection Details	
Noise	Check for abnormal noise from each part of machine as well as for sudden change in noise.	
Vibration	Check for excessively large vibration and for sudden change.	
Mounting parts and piping	Check the mounting bolts that fix each part in place and piping components for looseness.	
Hydraulic fluid	Leaks	Check the O-rings of the product, piping and actuators for hydraulic fluid leaks.
	Temperature	Is the temperature of hydraulic fluid in its tank unusually high?
	Quantity	Is the level of hydraulic fluid in its tank within the proper range?
	Dirt	Is the color of hydraulic fluid in its tank appropriate?

*Please check the above at a location away from the operating area of the machine.

Daily inspection procedure

- Step 1** Make sure that the machine is in a stopped state.
- Step 2** Check for leaks under the machine equipped with the product and under the surrounding area of the product.
- Step 3** Check that the mounting bolts that fixes the product are not loose and that the pipe connections are not loose.
Check that the level of hydraulic fluid is within the range indicated on its tank.
- Step 4** Check for abnormal hydraulic fluid discoloration.
- Step 5** After repeating the control lever push and pull, make sure that the control lever returns to neutral when you release it.
- Step 6** Put the machine into operation.
- Step 7** Check for abnormal noise, vibration, and hydraulic fluid leaks when the control lever is inactive.
- Step 8** By slowly operating the control lever, activate the actuator, and check for abnormal noise, vibration, and hydraulic fluid leaks.
- Step 9** Operate the control lever at the stroke end of the actuator to check for fluid leaks and temperature at each part of the machine.

9.3 Precautions for Storage after Use or after Installation of Set(s) of Control Lever Parts

This section describes the important points you should follow when storing the product after use or after installing a set of control lever parts.

NOTICE

- If the product needs long-term storage, periodically check its condition and apply rust prevention treatment as necessary. There is a risk of rust or corrosion.
- When storing the product for a long period of time, you should properly apply the grease recommended in Table 3-4 to the moving parts of the product.

Step 1 Make sure that a masking plug is attached to each port of the product.

Step 2 Apply the recommended grease to the moving parts of the control lever and the spool(s).

Step 3 Apply rust preventive agent, cover the product with a plastic bag or so and put it in the packing box.

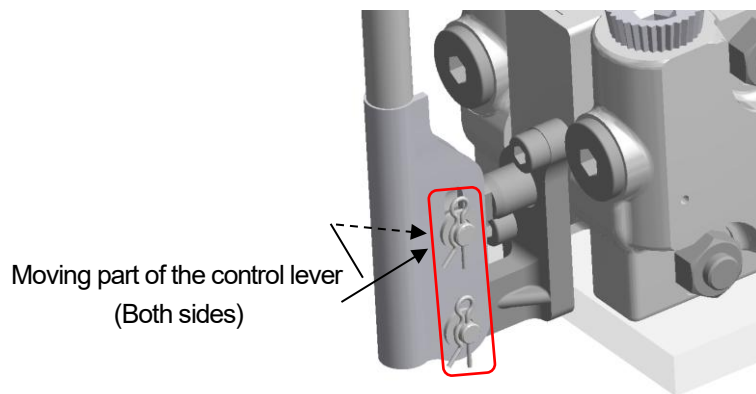

Fig. 9-1 Example of Grease Application

Chapter 10 Removal and Disposal

This chapter describes how to remove the product from the machine and dispose of it.



- When removing the product or pipes, place the machine in the position where the actuators do not move. Unintended activation of the machine may result in a personal injury accident.
- Do work on a dustproof and flat surface. If dust intrudes into the product or the hydraulic circuit, activation failure or malfunction of the machine may occur, resulting in a personal injury accident.
- To ensure the complete stop of the machine, keep the power source for the pump in the OFF state. If you do work while the power source for the pump is ON, there is a risk of a personal injury accident due to malfunction of the machine.
- First remove the set of control lever parts, remove pipes, and then remove the product from the machine. If you try to remove the product from the machine when the machine still has the set of control lever parts and pipes attached, they may interfere with the product removal, causing a personal injury accident due to activation failure and malfunction of the machine during the next installation of the product.



- Use a crane depending on the weight of the product. When it is used, a qualified person has to operate it.
- Workers should use tools suitable for their work. Using damaged or deteriorated tools, or using tools for purposes other than their intended use, may result in injury to the worker.
- Workers should wear appropriate clothing and protective equipment. When handling the product, there is a risk of injury.
- Do not touch the main body of the product or the hydraulic system until their temperatures drop after stopping the operation of the machine. Touching them may cause a burn injury.
- Do not work in an awkward position in an unstable place. There is a risk that the worker may hurt his/her back or a part of body.

10.1 Removal from Machine

- Step 1** Make sure that the power source for the pump is OFF.
- Step 2** To be prepared for leakage of hydraulic fluid, place an oil pan, waste cloth and so on.
- Step 3** Repeat the control lever push and pull to release the pressure in the valve.
- Step 4** To remove the set of control lever parts, reverse the procedure of 7.5 Mounting Set of Control Lever Parts.
- Step 5** Remove pipes. Attach the masking plug to the port from which pipe was removed.
- Step 6** Loosen the fixing bolts and remove the product from the machine. When removing, see 5.1 Precautions to Take When Carrying the Product.

10.2 Disposal Procedure

- Step 1** Place an oil pan.
- Step 2** Remove the masking plug in the oil pan and drain as much hydraulic fluid as possible out of the product.
- Step 3** Dispose of the hydraulic fluid. Ask an industrial waste disposal company for disposal.
- Step 4** Disassemble the product, separate and dispose of it. Ask an industrial waste disposal company for disposal.

Chapter 11 Troubleshooting

If abnormal noise, vibration, activation failure or other abnormal condition occurred, you have to check the following items.

IMPORTANT

- If you notice an abnormal symptom, you have to check whether the problem is caused by the product, pump, actuator, circuit, or controller.
For this purpose, it is necessary to measure pump discharge pressure and load pressure.

Symptoms	Probable Causes	Remedies
Fluid is leaking from control valve.	Main body is damaged.	Contact our customer service.
	Loose hose connector or damaged O-ring	Check the tightening torque of the hose connector or replace the O-ring.
	Pipe is damaged.	Replace pipe.
Actuator is not activated even when you operate control lever.	Wrong pipe connection	Check pipe connections.
	Relief valve malfunction	Contact our customer service.
All actuators are slow to operate even when control lever is moved to its full stroke.	Relief valve malfunction	Contact our customer service.
	Insufficient discharge flow rate of pump	Replace the pump.
Actuator is slow to operate because control lever cannot be moved to its full stroke.	Lever does not move due to sticking of actuator port module and spool, or debris jammed.	Contact our customer service.
Actuator is slow to respond when starting or stopping.	Pressure and flow rate used in the machine is greater than the product's rated ones.	Check pressure and flow rate of the machine.
Actuator is operating when the handle is not being operated.	Lever does not return to neutral due to sticking of actuator port module and spool, or debris jammed.	Contact our customer service.
Actuator is operating with control lever returned to neutral.	Clearance between actuator port module and spool became large.	Contact our customer service.

Contact Information

For requests for the product or after-sales service, please contact the following customer service.

In that case, please let us know the part number and serial number on the nameplate.



Comtesco Corporation

Contact Information

Tokyo Branch
Marketing & Sales Department

JA Kyosai Bldg., 7-9, Hirakawacho 2-chome,
Chiyoda-ku, Tokyo 102-0093, Japan

TEL: +81-3-5213-1152

E-mail : CMTJ_Contact@comtesco.com

HOMEPAGE: www.comtesco.com

Agency

If you have a contract with our company agency

(Name, address and contact information
of agency)