

RG Series

Hydraulic Motor with Reduction Gears Operation Manual

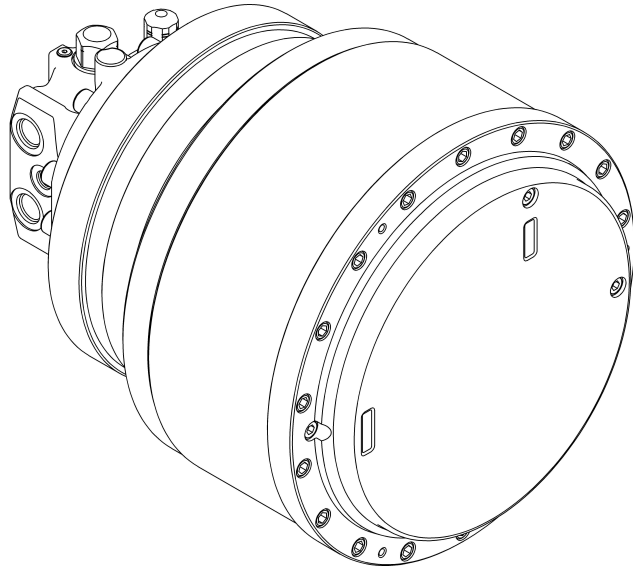

Please be sure to read and understand this manual before using the product
The administrator and operator of the product should have access to this manual.
Store this manual at a specified safe place so that it can be referred to when necessary.



A JV OF COMER INDUSTRIES AND NABTESCO

©Comtesco Corporation All Rights Reserved.

Table of Contents

CONTENTS OF MANUAL.....	3
IMPORTANT NOTICE.....	4
1. Intended Use of Product.....	4
2. Precautions for Safe Use of RG.....	4
3. Notice on the Operation Manual.....	5
4. Disposal of RG.....	5
5. Other Important Notice.....	5
Chapter 1 SAFETY.....	6
1.1. Strict observance and Prohibition.....	6
1.2. Types of Warnings and their Meanings.....	7
1.3. Notation and Meaning of Important Information.....	7
Chapter 2 OVERVIEW OF RG.....	8
2.1. Name of Each Part.....	8
2.2. Storage of RG.....	9
Chapter 3 PREPARATION FOR INSTALLATION.....	10
3.1. Installation Environments.....	10
3.2. Preparation of Necessary Materials.....	10
3.3. Transportation and Unpacking.....	11
Chapter 4 INSTALLATION IN THE MACHINE.....	14
4.1. Precautions on Hoisting.....	14
4.2. Hoisting and Installing RG.....	15
4.3. Hydraulic Piping Connection.....	17
4.4. Trial Run after Installation.....	18
Chapter 5 HYDRAULIC OIL AND LUBRICANT.....	19
5.1. Precautions when Handling Hydraulic Oil and Lubricant.....	19
5.2. Type of Hydraulic Oil.....	20
5.3. Replacing Hydraulic Oil.....	21
5.4. Type of Lubricant and Filling volume.....	22
5.5. Replacing Lubricant.....	23
Chapter 6 MAINTENANCE & INSPECTION.....	26
6.1. Precautions on Maintenance and Inspection.....	26
6.2. Periodical Inspection.....	26
6.3. Removal from the Machine.....	28
Chapter 7 TROUBLESHOOTING.....	29
CUSTOMER SUPPORT.....	31

CONTENTS OF MANUAL

This manual consists of the following chapters and references.

Chapter name	Description
IMPORTANT NOTICE	The following are explained: <ul style="list-style-type: none"> ▪ Intended use of the product ▪ Safety precautions ▪ Notice on the Operation Manual ▪ Disposal of RG ▪ Other important notices
Ch.1 SAFETY	The information on safety is described as strict observance and prohibition. Safety information such as RG installation is described in Chapter 3 and later.
Ch.2 OVERVIEW OF RG	The name of each part of RG as well as how to store it described.
Ch.3 PREPARATION	Installation environments of RG, preparation of necessary materials, unpacking, and hoisting are described, along with safety precautions.
Ch.4 INSTALLATION	Installation procedure of RG, and precautions to avoid human injuries during installation as well as damage of RG.
Ch.5 HYDRAULIC OIL AND LUBRICANT	The following information on hydraulic oil and lubricant is described: <ul style="list-style-type: none"> ▪ Precautions for handling ▪ Recommended brand ▪ Filling volume ▪ Replacing interval and procedure
Ch.6 MAINTENANCE & INSPECTION	Precautions for maintenance and inspection works, and procedure of periodical inspection and RG removal are described.
Ch.7 TROUBLESHOOTING	How to deal with problems is described.
CUSTOMER SUPPORT	Support contact at our corporation is described.

IMPORTANT NOTICE

1. Intended Use of Product

RG Series; Hydraulic Motor with Reduction Gears (hereafter referred to as RG) is a hydraulic driven rotary actuator. The product contains a reduction gears, a hydraulic motor, a brake valve and a parking brake integrated into one compact unit. It has been developed for use as an actuator for application requiring low-rpm, high torque operation such as construction and marine machinery.

The following conditions are to be satisfied for the use of RG.

- RG should be used within the specification and the limitation specified by our corporation. (Specifications and the limitation should be in compliance with those in confirmation notice (that is equivalent to delivery specification sheet) for RG or the specifications and operating agreement on the machinery for which RG is used.)
 - If it is used beyond the limitation range, it may cause abnormal wear due to poor lubrication or may cause damage due to seizure.
 - If RG is operated continuously at a high temperature, or at high load or high rotation speed, the life or performance decline and damage may occur.
- The product should be properly assembled in the customer's equipment. (Refer to p.14 in Chapter 4.)
- The proper lubrication condition should be maintained. (Refer to p.19 in Chapter 5.)
- The product should be installed in the environmental condition specified by our corporation. (Refer to p.10 on 3.1. in Chapter 3.)
- Make sure RGs of the same type are used when applying them facing each other or synchronizing.
 - To prevent damages of RG and the machinery, do not use RG of other type or other manufacturer's product.
- The following precautions should be observed:
 - When the end user is concerned with military or when the intended use is the manufacture of arms, the product may be regarded as an object of export regulation according to the Foreign Exchange and Foreign Trade Act in Japan. When exporting the product in this case, prepare review and necessary procedures.
 - Prepare an oil tray to prevent the lubricant from leakage due to malfunction or deterioration.

2. Precautions for Safe Use of RG

- Be sure to read this manual before use of RG.
 - NOTICE that this manual cannot cover all of the precautions related to safety. In transportation, installation and maintenance of RG, ensure to observe general safety precautions.
 - To prevent accidents, use the product only for the intended purpose. Avoid installation and maintenance work that are not specified or recommended in this manual.
 - Do not disassemble, repair, or modify the product, as it may cause malfunction or failure of the product. If disassembly or repair is necessary, contact our customer support.(Refer to p. 31)
 - Not only workers but also administrators should try to avoid any accidents.
 - The installation and maintenance of the product should be performed only by personnel with at least basic knowledge of the hydraulic motor and reduction gears and who have fully read and understood this manual.
 - Use of RG out of the intended use or without understanding the contents of this manual may cause the following hazard:
 - Hazard to life and health of the user.
 - Breakage of RG or the machinery incorporating RG.
-

- Wear hand protection such as leather gloves, prior to the handling because there is a risk of injury due to edges of the product that are not intended for manufacturing.
- If an operating qualification is required to operate the equipment incorporating the RG, and it needs to operate the equipment for installation, maintenance and inspection, a qualified person should operate. (ex. Vehicle-based construction machinery driving skills)

3. Notice on the Operation Manual

- This manual is intended for workers who are fluent in English. If this product is going to be operated or serviced by workers who are not fluent in English, the responsibility falls on the customer to provide thorough training on operation and safety.
- Ensure to operate the product according to the procedure and precautions specified and recommended in this manual. Any operation neglecting the described specification or recommendation may cause accidents and/or damage.
- This manual is copyrighted and all rights are reserved by our corporation. Any part of the drawings and technical references including in this manual shall not be copied, photocopied, or reproduced to any electronic medium or machine-readable form without prior consent of our corporation.
- The photographs and drawings described in this manual may not represent actual products strictly.
- If this manual is lost or damaged, immediately contact our customer support. Operating or servicing the product without this manual may result in accident.
- If you are going to transfer the product or machinery (attached or assembled in any way) to another party, be sure to submit this manual and related document to the new user.
- Reflect at least the description on lubricant (Chapter 5) and maintenance & inspection (Chapter 6) in this document to the operation manual for the customer machine into which RG is incorporated.

4. Disposal of RG

Disposal of RG and packaging materials may be regulated by laws and regulations in each country / region. In addition, recyclable materials are required to be reused.

When disposing, ask an industrial waste disposal contractor and follow these regulations.

If there is anything uncertain, please contact our customer support for processing.

5. Other Important Notice

- It is prohibited to analyze and use the product by any measure of reverse engineering or other related technology.
-

Chapter 1 SAFETY

The safety precautions are to be guidelines to avoid human accidents during the transportation, installation, and maintenance of RG, as well as to avoid damage to RG.

1.1. Strict observance and Prohibition

Overall precautions are classified into strict observance and prohibition.

For precautions at installation and maintenance, be sure to refer to the description of the corresponding chapter.

● **Strict observance**



- The transportation, installation, and maintenance should be performed only by personnel who understand the manual.
- The tools required for the work should be cleaned up to a specified place after work. Mixing a foreign object such as tools, screws and/or nuts may cause damage to the product.
- For handling of the hydraulic oil and the lubricant, refer to the indications and recommendations in this manual.

● **Prohibition**

- The work coordinator and/or administrator should not let personnel who have no ample knowledge of the product. It may result in an injury to the operator or damage to the product.
 - Do not put fingers or any foreign object at the opening end of the product. It may result in serious or moderate injury.
 - Do not modify or disassemble the product. It may result in breakage of the product.
 - Do not apply excessive impact or vibration to the product. It may cause breakage of the product.
 - The product may be very hot during operation. After the operation, do not touch the product until it has cooled down. Otherwise it may result in a heat-related injury.
 - Do not perform rapid cooling for high-temperature RG. When cooling, perform air cooling by atmospheric air.
 - Do not put any inflammable object around the product. It may result in fire.
 - If any abnormality or breakage should occur in the product, do not operate it until a proper countermeasure is prepared.
-

1.2. Types of Warnings and their Meanings

The following four types of warnings are used according to the expected hazards during operation and maintenance of the product. Neglecting such safety rules and warnings may cause accidents, resulting in serious injury and/or damage to this product.

Signal word	Meaning
 DANGER	Indicates an imminently hazardous situation which, if not avoided or prepared protection measures, will result in death or serious injury.
 WARNING	Indicates a potential hazardous situation which, if not avoided or prepared protection measures, could result in death or serious injury.
 CAUTION	Indicates a potential hazardous situation which, if not avoided or prepared protection measures, may result in minor or moderate injury.
NOTICE	Indicates a potential hazardous situation which, if not avoided or not prepared protection measures, may result in property damage.

1.3. Notation and Meaning of Important Information

Notation	Meaning
NOTE	Important matters or useful information for the RG operation, maintenance and inspection.

Chapter 2 OVERVIEW OF RG

2.1. Name of Each Part

Here is an drawings of the name of each part.

NOTE

The following drawings may not strictly represent the actual appearance of the product ordered.

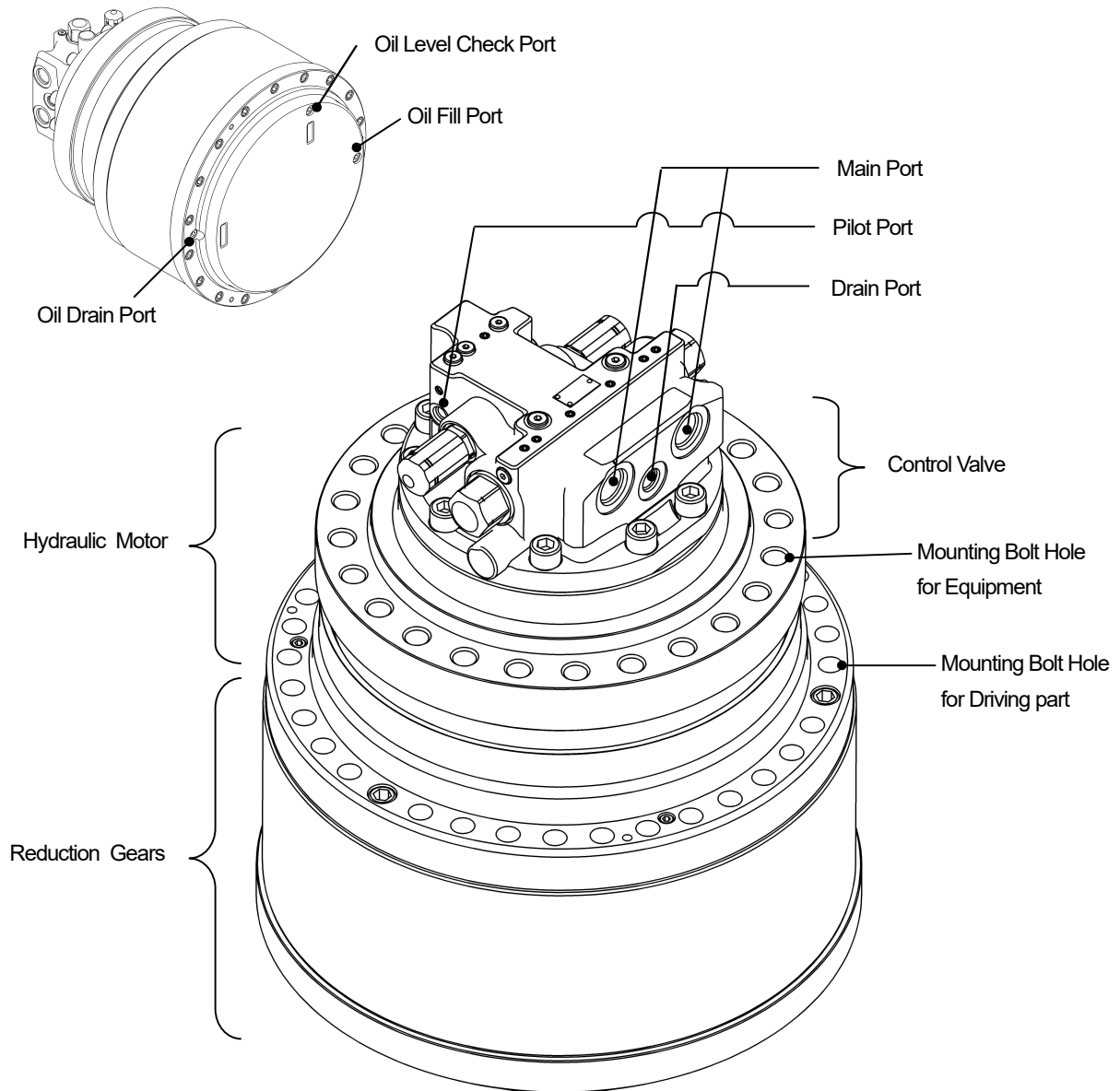

Fig 2-1

2.2. Storage of RG

NOTICE

When storing the RG, store it in the same packing condition as before unpacking (in a posture where the axis is horizontal). If the packing conditions change, foreign matter may enter the inside or rust may occur.

To avoid rust, corrosion, and deterioration of seals, avoid storage in places such as:

- Places where the surrounding temperature is under -10°C or over 40°C (Temperature recommended as the storage environment)
- Places of high humidity
- Places with direct sunlight
- Places where dew may condensate or freeze
- Outdoors with wind and rain directly
- Places near chemical substances such as an organic solvent, acid, and alkali
- Places exposed to corrosive gas and/or dust
- Places with unstable flooring
- Places where the floor strength is insufficient
- Places under vibration

NOTE

When the product is used or re-operated after a long-term, check the following:

- **That there is no rust or corrosion;**
Although RG has antirust oil applied to the outside before shipping, check the antirust state at least once a year. Take an antirust measure as necessary. The antirust state before shipping will be maintained for approx. twelve month.
 - **That seal parts has not been deteriorated over time.**
 - **That lubricant has not leaked.**
-

Chapter 3 PREPARATION FOR INSTALLATION

3.1. Installation Environments



WARNING

The installation environments should be in compliance with those specified in confirmation notice (that is equivalent to delivery specification sheet) for this product or the specifications and operating agreement on the machinery for which this product is used. Also, please do not use under the following environmental conditions. Using RG out of the specified environmental conditions may result in serious physical injury or fatal property damage.

- Places exposed to seawater or underwater
- Places exposed to toxic gases that may cause metal corrosion

3.2. Preparation of Necessary Materials

The installation of RG requires the following parts and materials.

Please prepare them after confirming the confirmation notice which includes installation drawing.

- **Mounting bolt**

The specifications and quantity of bolts required to mount RG are described in the confirmation notice.

If there is anything uncertain, please contact our customer support.

- **Hydraulic oil**

A small amount of hydraulic oil remains in RG at the time of shipment. It remains in the process of shipping inspection and does not affect the performance of the product.

For detailed information on the hydraulic oil, refer to Chapter 5 (p.19) and the Safety Data Sheet. For the Safety Data Sheet, contact our customer support or the supplier of the hydraulic oil.

- **Lubricant**

RG is filled with the lubricant specified by our corporation at the factory.

For detailed information on the lubricant, refer to Chapter 5 (p.19) and the Safety Data Sheet. For the Safety Data Sheet, contact our customer support or the supplier of the lubricant.

3.3. Transportation and Unpacking

3.3.1. Transportation



WARNING

- The mass of RG is heavy. Be sure to use transportation equipment such as a forklift to transport RG units.
- In transporting RG, handle it with ample care to avoid drops or falls. Otherwise it may result in injuries of the operator or damage to RG.
- For the personnel who carry out transportation, at least observe the following condition and wear the protective gear.
 - A forklift must be operated by a qualified person.
 - Be sure to wear a helmet, leather gloves and protective footwear.
- Be sure to check that RG is in the correct vertical orientation before unpacking the package. If it is turned upside down, the packaging material may be damaged, and RG may jump out and cause injury to workers.

NOTICE

Transport with the axis horizontal.

- **RG weight**

Refer to the confirmation notice.

3.3.2. Unpacking

NOTICE

Since RG has antirust oil applied to the outside before shipping, it may be slippery.
Wipe off the antirust oil before operation.

NOTE

- The illustrations (Fig.3-1) in this manual do not necessarily represent the individual packaging or the product. They change by the individual product or the confirmation notice. Also, for convenience, the drawings are cut out of the packaging material so that the contents can be imaged.
 - Reduction gears of RG is filled with lubricant specified by our corporation at the factory.
 - When hoisting RG, refer to the Hoisting RG section (Sections 4.1 and 4.2 on p.14 and p.15).
-

[Packing example 1]

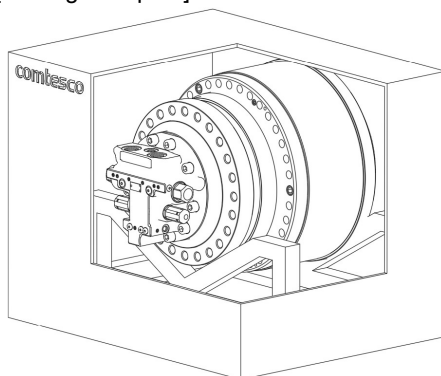

[Packing example 2]

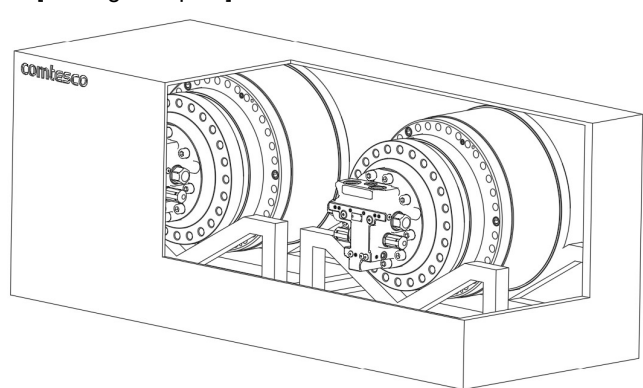

Fig. 3-1

- **Confirmation of contents**

Confirm the following before using the product:

Please contact our customer support if there is any delivery error or damage.

- The confirmation notice number matches the MS number on the nameplate, and the type code shown on the confirmation notice matches the type code shown on the nameplate. (Refer to nameplate contents p.13)
 - There was no breakage during transportation. (Refer to the confirmation notice.)
 - Check the confirmation notice and RG, there was no missing of the bolts by visual confirmation.
-

Chapter 4 **INSTALLATION IN THE MACHINE**

4.1. Precautions on Hoisting

 **CAUTION**

- The crane operation during hoisting must be conducted by a qualified person.
- Be sure to wear a helmet, leather gloves and protective footwear during hoisting work.
- The mass of RG is heavy. Use a hoisting tool robust enough to endure the mass of RG. If the strength of the hoisting tool is insufficient, the tool may be damaged and/or drop RG.
- Never get under RG while it is being hoisted.

 **WARNING**

Hoist RG body horizontally in a balanced manner. If it loses its balance and falls, operators may be injured or the customer's machine and RG may be damaged.

4.2. Hoisting and Installing RG

- Step 1** Check that there are no burrs or dirt on (1) Mounting surface for driving part of RG and RG mounting surface of the Driving part, and wipe off the antirust oil on (1) Mounting surface for driving part of RG and (2) Bolt seating surface of the Driving part.

NOTE

RG has antirust oil applied to the non-painted surfaces before shipping. To keep the transmitting torque by bolts high, wipe off the antirust oil on the mounting surface sufficiently.

- Step 2** Align (3) Mounting bolt hole for driving part of RG with the mounting holes of the Driving part, and assemble the Driving part into RG.

NOTICE

During the installation, do not hit RG with a hammer and the like.

- Step 3** Insert the flat washers and the mounting bolt for Driving part into (3) Mounting bolt hole for driving part of RG.

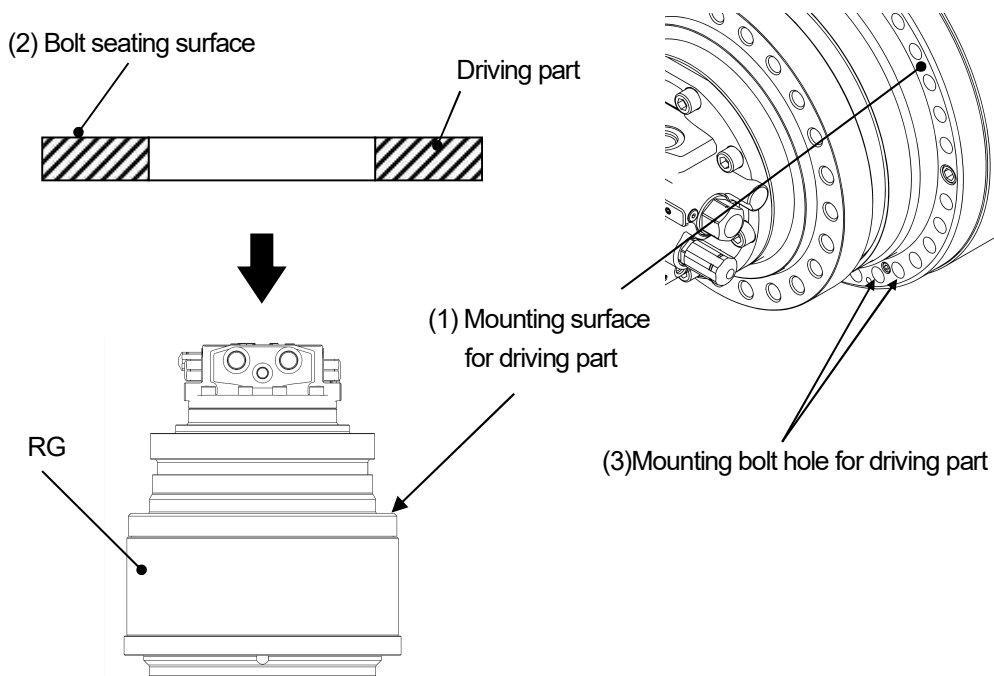

Fig. 4-1

NOTICE

Use the specified number of RG mounting bolts and tighten with the specified tightening torque. Otherwise, not only RG may not provide its performance but also the customer machine and RG may be damaged.

Step 4 Tighten the mounting bolts for Driving part uniformly with the specified tightening torque. Refer to the confirmation notice for the quantity and bolt size.

Table 4-1 Bolt tightening torque

Bolt size	M20(P2.5)	M22(P2.5)	M24(P3.0)	M30(P3.5)	M33(P3.5)
Tightening torque [N·m] (Recommendation)	559±58.8	696±69.0	902±88.3	1775±177	2305±235

Step 5 Attach the hoisting tool to RG.

Step 6 Hoist RG body.

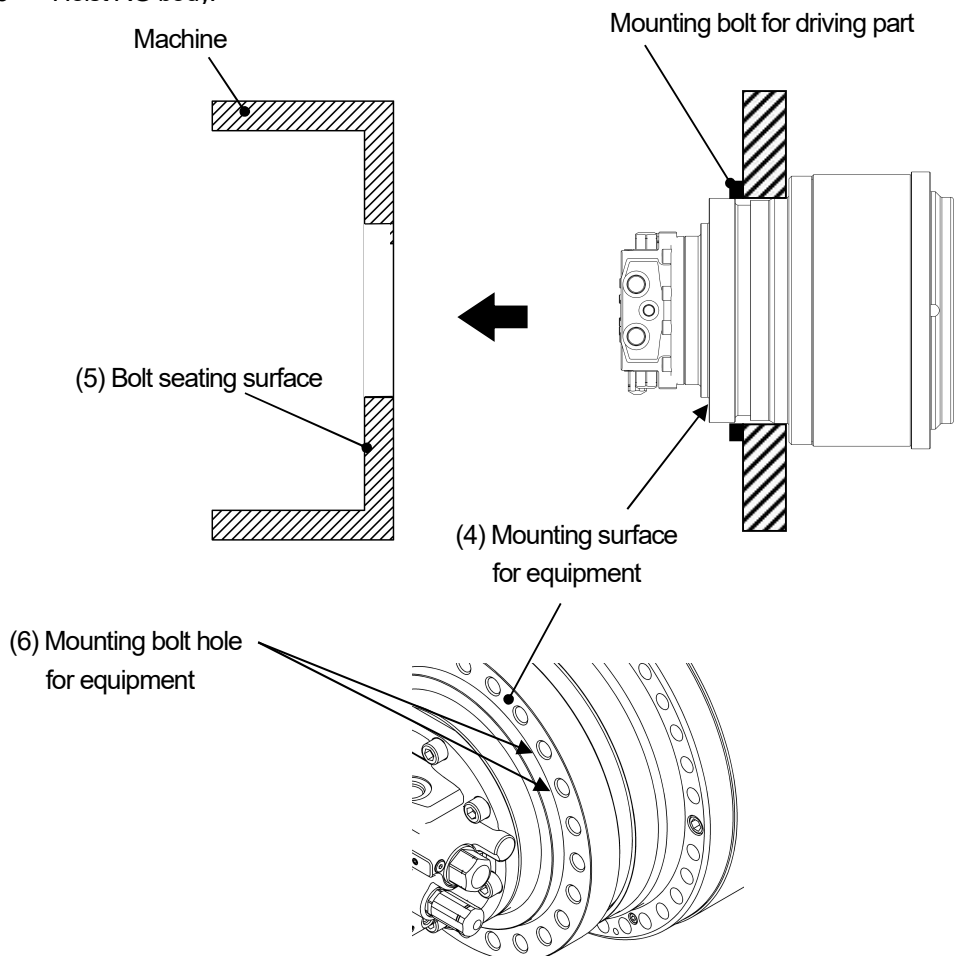

Fig. 4-2

- Step 7** Check that there are no burrs or dirt on (4) Mounting surface for equipment of RG and RG mounting surface of the Machine, and wipe off the antirust oil on (4) Mounting surface for equipment of RG and (5) Bolt seating surface of the Machine.

NOTE

RG has antirust oil applied to the non-painted surfaces before shipping. To keep the transmitting torque by bolts high, wipe off the antirust oil on the mounting surface sufficiently.

- Step 8** Align (6) Mounting bolt hole for equipment of RG with the mounting holes of the Machine, and assemble RG into the Machine.

NOTICE

During the installation, do not hit RG with a hammer and the like.

- Step 9** Insert the flat washers and the mounting bolts into (6) Mounting bolt hole for equipment of RG.

NOTICE

Use the specified number of RG mounting bolts and tighten with the specified tightening torque. Otherwise, not only RG may not provide its performance but also the customer machine and RG may be damaged.

- Step 10** Tighten the mounting bolts for equipment uniformly with the specified tightening torque. (Refer to Table 4-1 on p.16) Refer to the confirmation notice for the quantity and bolt size.

4.3. Hydraulic Piping Connection

After installing RG, connect hydraulic piping.

- Step 1** Remove the covers or plugs attached to the port.
- Step 2** Fill the motor casing with hydraulic oil. Refer to the confirmation notice P.21 for the Filling of hydraulic oil.

NOTICE

Fill the motor casing with hydraulic oil before use. If RG is operated without supplying hydraulic oil, the product may be damaged.

- Step 3** Connect each hydraulic piping.
-

NOTICE

- Confirm RG piping port, rotation direction, and piping size in the confirmation notice.
 - Select the piping size so that the drain port back pressure is below the pressure described in the confirmation notice.
-

4.4. Trial Run after Installation

After installing RG on the customer's equipment and piping it, check that the rotating direction is the intended direction. Also, follow the note below and operate safely after running-in RG.

NOTE

In the running-in operation, use the engine of the equipment in low idling and keep idling for 5 minutes or more to remove the inside air with RG at 1st speed.



CAUTION

- Never approach the rotating part during machine operation. Person(s) may be caught by the rotating part, causing fatal accidents.
- RG may become hot during operation. After stopping the operation, do not touch RG until it has cooled down.
- Immediately stop operation when any abnormality occurs. Continuous operation may cause injuries to the operator.
- Observe RG specifications and the limitation of specifications specified by us.
(Specifications and the limitation should be in compliance with the confirmation notice for RG or the specifications and operating agreement for the machine for which RG is used.)

NOTICE

Do not perform rapid cooling for high-temperature RG. When cooling, perform air cooling by atmospheric air.

Chapter 5 HYDRAULIC OIL AND LUBRICANT

This chapter describes hydraulic oil and lubricant. The description on hydraulic oil and lubricant (this chapter) in this document should be reflected at least to the operation manual for the customer's machine into which RG is incorporated.

CAUTION

- When replacing the hydraulic oil and lubricant, turn off the power to the customer machine.
- RG may become hot during operation. After stopping the operation, do not touch RG until it has cooled down. If the oil fill port and oil drain port are unplugged in the high-temperature state, the high-temperature lubricant may blow out accidentally due to the pressure change in the reduction gears, which can cause burn injury.

NOTICE

- RG is filled with the lubricant at the factory. Filling up the lubricant excessively may result in heat generation and leakage of the lubricant.
 - RG is drained hydraulic oil at the time of shipment. Be sure to fill the motor casing with hydraulic oil before operation.
 - If the amount of the lubricant has decreased due to some reason, identify and remove the cause, and then add the lubricant.
 - When draining the lubricant, do not drain it on the ground. Be sure to drain it into a container. Disposal of the waste oil should be in accordance with the applicable laws and regulations.
 - Do not perform rapid cooling for high-temperature RG. When cooling, perform air cooling by atmospheric air.
-

5.1. Precautions of Hydraulic Oil and Lubricant

- **Precautions when handling hydraulic oil and lubricant are as follows:**
 - Before handling hydraulic oil and lubricant, be sure to read the precautions described on the case/bottle of each for correct use. Wrong usage may cause fatal accident.
 - Be sure to wear protective goggles in order to prevent hydraulic oil and lubricant from entering into eyes.
 - Be sure to wear rubber gloves to prevent hydraulic oil and lubricant from contacting your skin.
 - Do not eat or put hydraulic oil and lubricant into your mouth.
 - For detailed information, refer to Safety Data Sheet of hydraulic oil and lubricant. Ask to the Safety Data Sheet from our Customer Support or the purchaser of hydraulic oil and lubricant.
-

● **Emergency measure:**

- If hydraulic oil or lubricant comes into contact with eyes, flush for 15 minutes with clean water and seek medical treatment.
- If hydraulic oil or lubricant comes into contact with skin, wash affected area with water and soap.
- If hydraulic oil or lubricant is swallowed, do not induce vomiting and seek medical treatment immediately.

● **Disposal of waste oil and container:**

- Proper disposal is required by laws and regulations. Follow the laws and regulations.
- Consult the purchaser of hydraulic oil and lubricant for assistance or advice if any uncertainty arises.

● **Storage**

- To avoid any foreign object or water from being mixed in, seal container of hydraulic oil and the lubricant after use.
- Avoid direct sun light, keep away from fire or heat sources, and store in a cool and dark place.

5.2. Type of Hydraulic Oil

NOTICE

Use the hydraulic oil recommended by us. Use of any other hydraulic oil may degrade the performance and durability of RG.

● **Hydraulic oil specified by Comtesco**

- Use a wear-resistant hydraulic oil with a viscosity equivalent to ISO VG32 to VG68.
- The cleanliness of hydraulic oil should be maintained within level NAS9.
- The recommended brands are as follows.

Grade	Viscosity (40[°C])	32[mm ² /s]	46[mm ² /s]	68[mm ² /s]
	JIS		VG32	VG46
Manufacturer name	Idemitsu Kosan	Daphne Super Hydro A32	Daphne Super Hydro A46	Daphne Super Hydro A68
	Exxon Mobil	Mobil DTE24	Mobil DTE25	Mobil DTE26
	ENEOS	SUPER HYRANDO 32	SUPER HYRANDO 46	SUPER HYRANDO 68
	Cosmo Oil	Cosmo Hydro AW32	Cosmo Hydro AW46	Cosmo Hydro AW68

● **Filling of hydraulic oil**

- The motor case shall be filled with hydraulic oil prior to the operation. (Use non-plugged drain port for filling.)
- Because each piping contains air, after installing the unit to the host machine, the trial run for 5 minutes shall be performed at the beginning of the initial operation of the unit with the motor at low speed mode and the engine at low-idle mode.

● **Temperature and viscosity range of hydraulic oil**

Make sure that the operating temperature range and viscosity range of the hydraulic oil do not exceed the following ranges.

- Operating temperature range : -20~+90 [°C]
- Practical viscosity range : 15~500 [mm²/s]

NOTICE

When using with a viscosity of 500 [mm² / s] or more, the motor may not be able to suck oil and may cause malfunction. In addition, if the viscosity is less than 15 [mm² / s], the performance will decrease significantly, and if it is used for a long time, the motor sliding part may get damaged, resulting in a permanent deterioration in performance.

5.3. Replacing Hydraulic Oil

● **Replacement interval**

- Replace with new oil every 1000 engine hours or 1 year.
- If the deterioration of the hydraulic oil is severe even within the above replacement interval, replace it according to the following standard.

Test items		Replacement criteria
Viscosity change (40[°C])	[mm ² /s]	Within ±10[%]
Total oxidation	[mgKOH/g]	Consult with the hydraulic oil manufacturer because it depends on the oil type and manufacturer.
Water content	[%]	Within 0.1
Impurities	[mg/100mL]	Within 10
Insoluble content	[%]	Within 0.05
Color	—	Drastic change

- **Replacement procedure**

Replace and replenish according to hydraulic oil replacement and replenishment procedure of the machine.

NOTICE

Use the same hydraulic oil brand for replacement and replenishment, and do not mix different brands.

5.4. Type of Lubricant and Filling volume

NOTICE

Use the lubricant recommended by us. Use of any other lubricant may degrade the performance and durability of RG.

- **Lubricant specified by Comtesco**

Use a lubricant with extreme-pressure additive equipment to SAE #90 (API class GL-4 or higher).The following brands are recommended.

Manufacturer name	Product name
ENEOS	Gear Oil GL-4 90
Idemitsu Kosan	Apolloil Gear HE90
Exxon Mobil	Mobilube HD80W-90
Shell	Shell Spirax EP90
Cosmo Oil	Cosmo Gear GL-4 90

- **Filling volume lubricant**

Prepare lubricant according to the amount of lubricant in the confirmation notice.

- **Temperature range of lubricant**

Operating temperature range : -20 ~ +70 [°C]

5.5. Replacing Lubricant

● Replacement interval

- Replace with new oil at 500 engine hours first, after that every 1000 engine hours. Replace the lubricant if it has been in stock for a long time (1 year or more).
- If the lubricant deteriorates severely even within the above replacement interval, replace it according to the following standard.

		Replacement criteria	Probable cause
Viscosity change (40[°C])	[mm ² /s]	Within 10% compared with new oil	Progress of oxidative degradation Mixing of different oils
Water content	[%]	Within 0.2	External contamination
Pentane insoluble matter	[%]	Within 1.0	Oxide, carbon, additives, wear powder, dust, and so on. from outside
Total oxidation	[mgKOH/g]	0.5 increase compared with new oil	Progress of oxidative degradation
Metal analysis	Al	[ppm]	Within 150
	Cr	[ppm]	Within 20
	Cu	[ppm]	Within 20
	Fe	[ppm]	Within 600
	Si	[ppm]	Within 350

● Replacement procedure



CAUTION

- Confirm that the power of the customer machine is turned off before beginning the replacement work.
- Immediately after operation, RG and lubricant may be hot and may cause burns if touched. Work after the temperature has dropped sufficiently.
- Lubricant may eject when removing the reduction gears plug to supply and drain oil. Please work with great care, such as slowly removing the plug to relieve internal pressure.
- Be sure to wear protective goggles and rubber gloves.
- Do not replace/replenish the lubricant in a subfreezing environment. Failure to observe this may result in frostbite. Also, if the lubricant is replaced/replenished in a subfreezing environment, the temperature difference from the operating temperature increases and the pressure increase in the reduction gears may cause oil leakage.

NOTICE

Do not perform rapid cooling for high-temperature RG. When cooling, perform air cooling by atmospheric air.

NOTICE

**Use the same lubricant brand for replacement and replenishment, and do not mix different brands.
When changing the oil type, flush the inside of reduction gears.**

Replace or replenish the lubricant according to the following procedure. Also, work with RG in the posture with the oil fill port up and the oil drain port down as shown below.

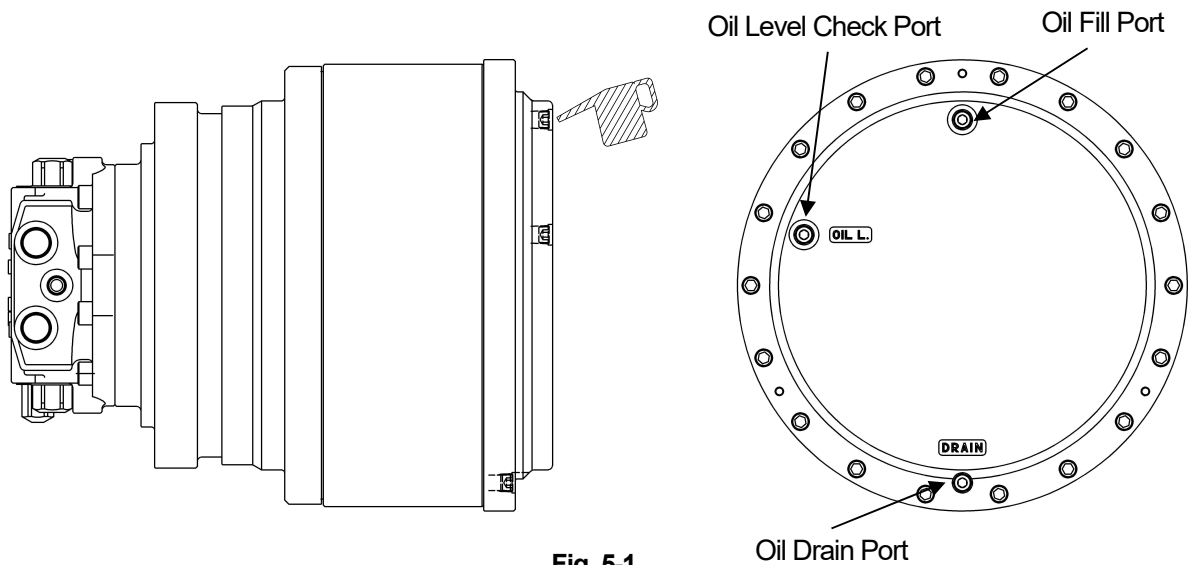

Fig. 5-1

Step 1 When replacing, remove the plug of the oil fill port, oil drain port, and oil level check port, and drain the lubricant. When replenishing the lubricant, do not remove the plug of the oil drain port.

NOTICE

- Receive the drained lubricant with a container.
- If there is sealing tape on the tapered screw hole after removing the plug, remove it completely.

Step 2 After the completion of drainage, plug the oil drain port, and tighten the plug with the specified tightening torque (p.25 Table 5-3).
(Refer to the confirmation notice for plug size.)

Step 3 Fill up the lubricant from the oil fill port.
Referring to the amount of filled lubricant described in the confirmation notice.
(The Oil Level Check Port is a reference for oil level.)

NOTE

If the lubricant is filled up excessively, the inner pressure increases, which can cause a leakage of the lubricant or damage to the oil seal.

When the lubricant is small in amount, insufficient lubrication may cause damage to RG.

Step 4 When filling is complete, insert the plug into the oil fill port and oil level check port, and tighten with the specified tightening torque. (Refer to the confirmation notice for the plug size.)

Table 5-3 Plug size and tightening torque

Size	R1/2	R3/4
Tightening torque [N-m]	58.8±19.6	98.1±9.81

NOTICE

After checking that the R plug is clean, wrap it properly with new sealing tape and then assemble it.

Step 5 If the lubricant has adhered to the periphery, wipe it off sufficiently.

Chapter 6 MAINTENANCE & INSPECTION

This chapter describes the maintenance and inspection. Reflect at least the description on maintenance & inspection (this chapter) in this document to the operation manual for the customer machine into which RG is incorporated.

6.1. Precautions on maintenance and inspection

CAUTION

- Turn off the power to the customer machine before starting maintenance and inspection. If maintenance or inspection is performed during machine operation, person(s) may get burned due to high temperature or be caught by the rotating part, causing fatal accidents.
- Do not perform maintenance and inspection in a subfreezing environment. Failure to observe this may result in frostbite. Also, if maintenance or inspection is performed in a subfreezing environment, the temperature difference from the operating temperature increases and, as the result, the increased pressure in the reduction gears may cause oil leakage.
- RG may become hot during operation. After stopping the operation, do not touch RG until it has cooled down.
- Wear appropriate clothing and appropriate protective equipment (protective goggles, protective gloves, and protective footwear).
- Abnormal noise should be checked during operation. Never touch the machine during the check.

NOTICE

Do not perform rapid cooling for high-temperature CS. When cooling, perform air cooling by atmospheric air.

6.2. Periodical Inspection

● Periodical inspection list

Inspect the following items at least once in a year.

Lubricant must be replaced based on the operating time. Refer to Section 5.5 Replacing Lubricant (p.23) and replace as appropriate. For hydraulic oil, replace it appropriately referring to Section 5.3 Replacing Hydraulic Oil (p.21).

No.	Inspection item	Description	Reference
1	Leakage of lubricant	Check whether there is not a leakage of lubricant from the mating surface around RG and floating seal section.	6.2.1.
2	Bolt looseness	Check whether each mounting bolt is not loose.	6.2.2.
3	Abnormal noise	Check whether there is not any abnormal noise or sudden change in sound.	6.2.3.
4	Surface temperature of RG	Check whether surface temperature of RG is abnormally high.	6.2.4.

- **Necessary tools**

The typical tools required for maintenance and inspection are listed below.

- Hexagon wrench
- Wrench
- Torque wrench
- Surface thermometer

6.2.1. Checking for lubricant leakage

Visually check the periphery of the reduction gears, joint surface with the machine, and the entire machine to make sure that there is no leakage of the lubricant.

If a leakage of the lubricant has been found, identify and remove the cause, and then replenish the lubricant.

NOTICE

The adhering dirt and sand may cause seizure, heat generation, or protrusion, and the lubricant may leak due to the loss of the sealing performance of the floating seal.

6.2.2. Inspecting the mounting bolts

Check looseness of the mounting bolts for equipment and the mounting bolts for driving part. If any are loose, retighten with the specified tightening torque. (Refer to p.16 Table 4-1 for the tightening torque.)

6.2.3. Checking for abnormal noise

 **CAUTION**

Abnormal noise should be checked during operation. Never touch the machine during the check.

Step 1 Be careful not to touch RG and check abnormal noise or sudden changes in sound.

Step 2 If any abnormal noise has been detected, report it to the administrator and stop the machine operation.

6.2.4. Inspecting the surface temperature

Measure the surface temperatures of the motor and reduction gears to check whether they are not over the standard temperature. Perform the measurement after continuous operation.

- Step 1** Using a surface thermometer, measure the surface temperature at the measurement point shown in the following figure below and the surrounding area to check the maximum value.

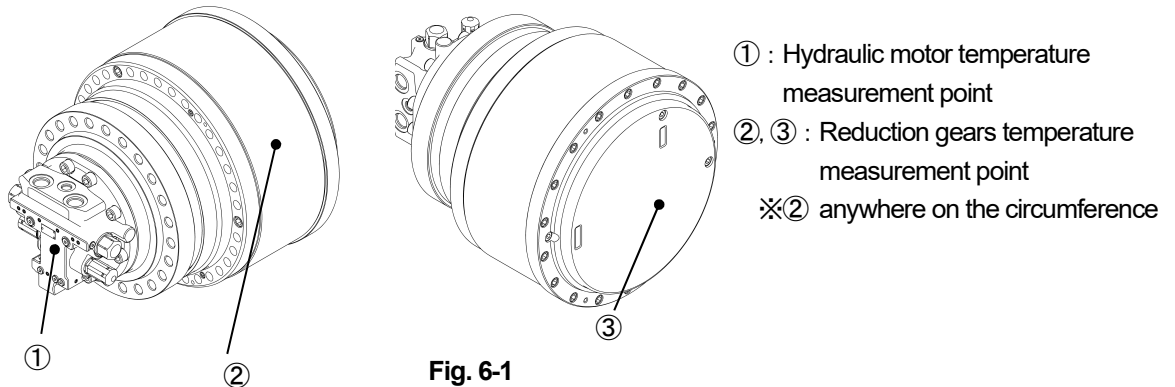

NOTE

For the method of using the surface thermometer, refer to the operation manual attached to the product you use.

- Step 2** If the surface temperature is more than 70°C, report it to the administrator and stop the machine operation.

Standard surface temperature of hydraulic motor and reduction gears in continuous operation :
Maximum 70°C

6.3. Removal from the Machine

If it is necessary to remove RG from the machine for maintenance, inspection, or replacement, pay the following precautions and remove it in the reverse procedure described in Section 4.2 Hoisting and Installing RG (refer p.15).

CAUTION

- To remove RG, hoisting by crane operation is needed. Before starting the removal, refer to “4.1 Precautions on Hoisting” (p.14) to confirm the precautions on hoisting and work procedure. Hoist RG in accordance with the description.
- Make sure no torque remains on RG before starting work.

Chapter 7 TROUBLESHOOTING

If there is any problematic phenomenon, check the cause and take measures according to the following table.

If the measure marked with a circle is needed, stop the machine operation and contact our customer support.

For the item marked with a circle, contact our customer support.

Phenomenon 1	Phenomenon 2	Probable cause		Treatment		
Does not rotate	Pressure never increase	Malfunction of built in relief valve		Repair or Replace	○	
		Low set pressure of the relief valve		Set the pressure correctly		
		Malfunction of the pump		Repair		
		Malfunction of the direction-switching valve		Repair		
	Pressure increase	Parking brake is not released	Blockage of the oil passage by contaminants		Repair or Replace	○
			Brake valve parts are wrong direction		Repair	○
			Stuck part of parking brake		Repair or Replace	○
Seizure of sliding portion		Repair or Replace	○			
Output torque weakly at startup	Set pressure of overload valve is correct, but brake is released belatedly	Malfunction of the brake valve		Repair or Replace	○	
	Parking brake is released, but motor is hard to start	High oil viscosity		Raise oil temperature		
	Parking brake is released, but motor starts weakly	Parking brake is not completely released (Clogging of choke of pressure release passage)		Repair or Replace	○	
		Relief valve catches small particles		Wash relief valve or replace	○	
		Seizure of sliding portion		Repair or replace sliding portion	○	
Drive shaft never rotate up to the set value	Shortage of oil coming in		Check the pumps discharging volume and oil passage			
	Large wear or flaw made on sliding portion		Repair or replace of parts	○		

Brake refuses to work	Brake does not work	Malfunction of the parking brake	Repair or Replace	○
	Brake valve works	Malfunction of the brake valve	Repair or Replace	○
Oil leakage		Loose bolt or plug	Tight it with specified torque	
		O ring is torn off	Replace	○
		Floating seal is damaged	Replace	○
Would not shift from high to low or low to high speed		Stick or worn of parts	Repair or Replace	○
Abnormal noise	Abnormal noise appear together with big vibration when brake is slowly applied or oil is supplied to other circuits while motor is running	Air is caught inside brake valve	Bleeding air	
		Malfunction of the brake valve	Repair or Replace	○
Hunting occurs while descending the slope	Severe hunting while inching	Malfunction of the brake valve	Repair or Replace	○

CUSTOMER SUPPORT

For inquiries related to products and servicing, please contact customer support (see the following addresses):

For inquiries, be ready to provide the product information described on the nameplate attached on the product.



Comtesco Corporation

Tokyo Branch

Sales

7-9 2-chome, Hirakawa-cho,
Chiyoda-ku, Tokyo 102-0093, Japan
Telephone: +81-3-5213-1152
E-mail: CMTJ_Contact@comtesco.com
HOMEPAGE www.comtesco.com

Sales Representatives

When contacted by a sales representative;

(Name and address here)